

**MAGNETI  
MARELLI**

PARTS & SERVICES



**Workshop Equipment Catalog**

# THE AREA OF OPERATION OF OUR TECHNICIANS

**PRZEMYSŁAW ZALEWSKI**  
 PRZEMYSLAW.ZALEWSKI@MARELLI.COM  
 +48 604 275 975

**WOJCIECH WIECHEĆ**  
 WOJCIECH.WIECHEC@MARELLI.COM  
 +48 602 778 926

**GRZEGORZ TOCZYŃSKI**  
 GRZEGORZ.TOCZYNSKI@MARELLI.COM  
 +48 600 254 237



**Contact Information**  
 workshop.export@marelli.com  
 www.magnetimarellii-parts-and-services.pl

## Contact Information for Our WE Magneti Marelli Service Department

**Krystian Marczewski** +48 668 686 120 krystian.marczewski@marelli.com  
**Artur Mrugała** +48 664 095 718 artur.mrugala@marelli.com

WE Service



WE Catalogue



Table of contents

## Workshop equipment catalogue

### AIR CONDITIONING

|                                   |       |
|-----------------------------------|-------|
| ▶ Alaska BeCool                   | 6-7   |
| ▶ Alaska Prime H / Alaska Prime R | 8-9   |
| ▶ Alaska Evo H / Alaska Evo R     | 10-11 |
| ▶ Alaska Bus                      | 13    |
| ▶ ACHECK500                       | 15    |
| ▶ ACHECK600                       | 16    |
| ▶ FILTERS                         | 18-19 |
| ▶ REFPRO 5.0                      | 20    |
| ▶ OZONATOR M-MX                   | 21    |
| ▶ BACTOBAN                        | 22    |
| ▶ MM AC Guard and FILTER KIT      | 23    |
| ▶ HYDROGEN KIT                    | 27    |
| ▶ AC FLUSH PRO / SUPER FLUSH      | 30    |
| ▶ OILS / Lubricants               | 36-41 |

### DIAGNOSTICS

|   |    |
|---|----|
| ▶ DATA BOX, DATA BOX SGW                        | 44 |
| ▶ DATA PLUS, DATA PLUS SGW                      | 44 |
| ▶ MM VOLANTE 3D                                 | 46 |
| ▶ MM VOLANTE 3D AUTO                            | 47 |
| ▶ RETIS, RETIS TRUCK                            | 48 |
| ▶ AUTODATA - DIAGNOSTICS AND REPAIR             | 49 |
| ▶ PREMIUM HEADLAMP ALIGNER                      | 50 |
| ▶ SMART ANALOG HEADLAMP ALIGNER                 | 51 |
| ▶ MASTER ALT 2                                  | 53 |
| ▶ ALT DIAG PRO                                  | 54 |
| ▶ POWER M120                                    | 55 |
| ▶ EASY BAT                                      | 56 |
| ▶ BAT EXPERT PRO 2.0                            | 57 |
| ▶ BAT EXPERT 100                                | 58 |
| ▶ BAT-5 PRO                                     | 59 |
| ▶ MAGNETI MARELLI ES.3 / ESX                    | 60 |
| ▶ OXHYDRO CARBON CLEANER                        | 61 |
| ▶ DIAGNOSTICS - PETROL INJECTOR TESTERS GS4/GS8 | 62 |
| ▶ DIESEL INJECTOR TESTERS GDRX, GDU4RX          | 63 |
| ▶ DIESEL INJECTOR TESTERS GTB4RX                | 64 |

### ELECTRIC VEHICLE OPERATION

|  |    |
|--|----|
| ▶ TESTER EVCHECK 1000 / EVCHECK 800    | 66 |
| ▶ MM E-LIFT 1.2 - HV BATTERY LIFT 1,2t | 67 |
| ▶ MM E-LIFT 1.0 - HV BATTERY LIFT 1t   | 35 |
| ▶ REPAIR TOOL KIT                      | 68 |
| ▶ SERVICE STATION MARKING KIT          | 69 |

### DIESEL

|   |    |
|---|----|
| ▶ DSRX / CRU2RX INJECTOR TESTERS            | 72 |
| ▶ ITB1RX / ITB4RX INJECTOR TESTERS          | 73 |
| ▶ MTBRX / PTBRX injector and pump tester    | 74 |
| ▶ ETBRX control and measurement module      | 75 |
| ▶ ACCESSORIES FOR INJECTOR AND PUMP TESTERS | 76 |

### CAR LIFTS

|                                  |    |
|----------------------------------|----|
| ▶ MM SUPERLIFT 4000B/4000BS/220V | 78 |
| ▶ MM SUPERLIFT 5000B             | 79 |
| ▶ MM SUPERLIFT 4000UC/220V       | 80 |
| ▶ MM SUPERLIFT 6000UC            | 81 |
| ▶ MM MMUH45M                     | 82 |
| ▶ MM MMUZ30LM                    | 83 |
| ▶ MM MMUZ30Y                     | 84 |
| ▶ MM MMUB30Y                     | 85 |
| ▶ MM SUPERLIFT 5000SC/5000SCX    | 86 |
| ▶ MM SUPERLIFT 5500QCLP          | 87 |

### WORKSHOP EQUIPMENT

|                        |    |
|------------------------|----|
| ▶ ATF EXTRA PRO        | 90 |
| ▶ MM TC-200            | 91 |
| ▶ MM ATF INFOTEK       | 92 |
| ▶ CONNECTORS, ADAPTERS | 93 |
| ▶ TIRE CHANGERS        | 95 |
| ▶ WHEEL BALANCERS      | 96 |
| ▶ POWERGY 2500         | 98 |

### TOOLS, WORKSHOP CHEMISTRY

|  |     |
|--|-----|
| ▶ OIL EXTRACTORS / OIL EXTRACTORS / OIL EXTRACTORS | 102 |
| ▶ DEVICE FOR DISTRIBUTING OIL AND FLUIDS           | 102 |
| ▶ BATHTUBS   | 104 |
| ▶ MAGNETI MARELLI PNEUMATIC IMPACT WRENCHES        | 106 |
| ▶ CORDLESS IMPACT WRENCHES                         | 107 |
| ▶ WORKSHOP LAMPS                                   | 108 |
| ▶ HYGIENE PRODUCTS                                 | 111 |
| ▶ DEGREASERS                                       | 112 |
| ▶ GLOVES   | 113 |
| ▶ CLOTHING   | 114 |

### TECHNICAL TRAININGS

|             |     |
|-------------|-----|
| ▶ TRAININGS | 115 |
|-------------|-----|



**HAVE A QUESTION?**

**CALL**



**CONTACT US**

**SCAN!**

Y  
E  
S



# AIR CONDITIONING

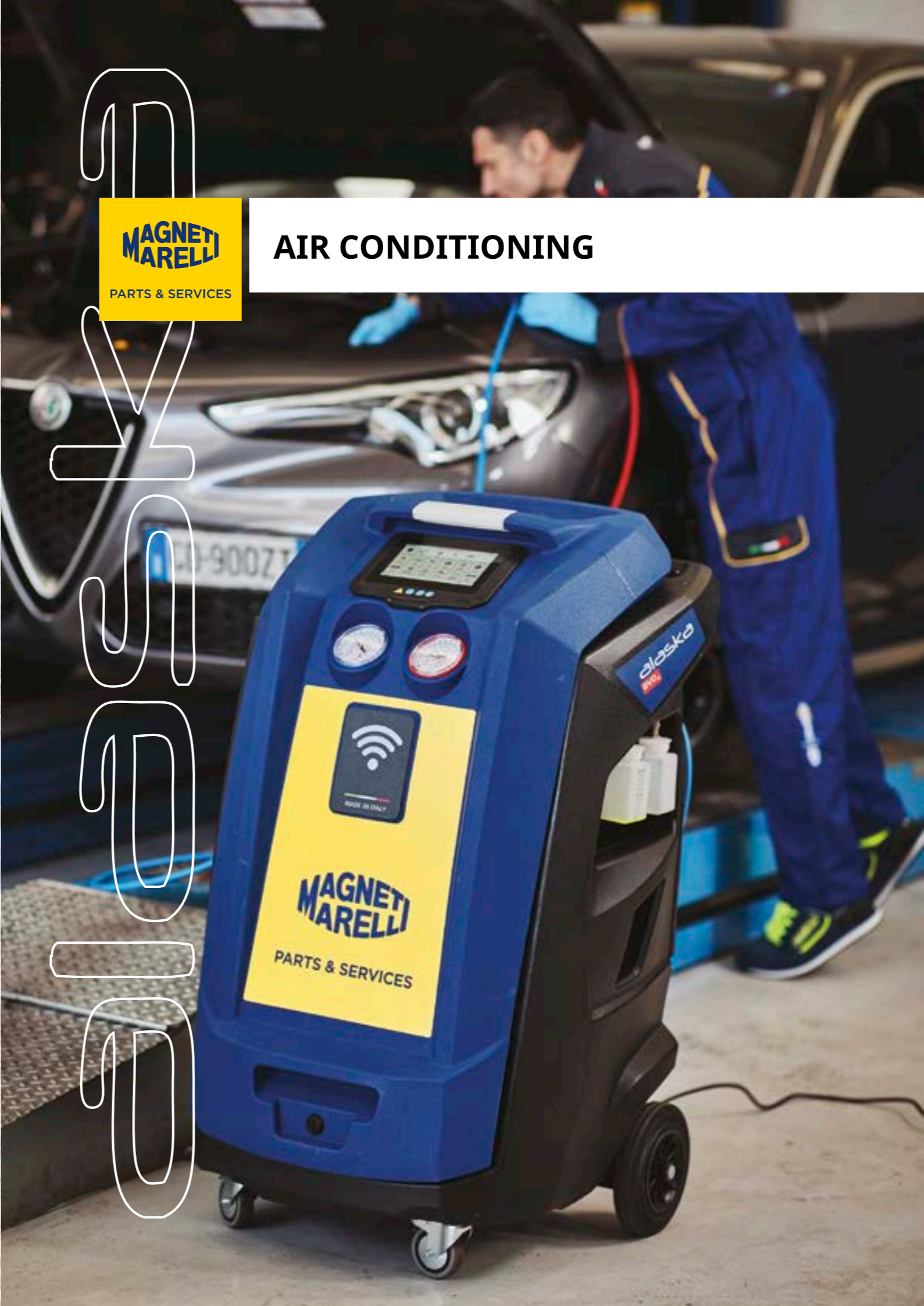

# Alaska BeCool R1234yf

## Air conditioning service station

NEW

In response to market demand for proven yet cost-effective air conditioning service stations, Magneti Marelli presents its new Alaska BeCool range. In the automotive service sector, the efficiency of air conditioning operations is becoming increasingly important for workshops and service networks. This is why ALASKA BeCool was created: a new range of air conditioning service stations, designed for high performance, dedicated to servicing the 'new' and 'old' refrigerants R-134a (R) and R-1234yf (H), which are now the market standard.

007950015760



Made in Italy



Alaska BeCool



### Key benefits

- ✓ Reliable and robust construction
- ✓ High-performance solutions
- ✓ Easy to use and transport
- ✓ Compact dimensions
- ✓ 10 kg cylinder with 'Anti-shock' system
- ✓ Built-in vehicle database
- ✓ Two versions: for old and new refrigerants

# Alaska BeCool R134a

## Air conditioning service station

NEW

007950015770



Made in Italy



### TECHNICAL SPECIFICATIONS

- ▶ Dimensions: 90 x 50 x 65 mm
- ▶ Power supply: 230V 50/60Hz
- ▶ Motherboard: Semi-automatic
- ▶ Display: 4x20 5mm
- ▶ Compressor: 14cc
- ▶ Vacuum pump: 70 l/min
- ▶ Tank: 10 kg
- ▶ Heating belt: optional
- ▶ Keyboard: 4 buttons
- ▶ Car database: Integrated
- ▶ Updates: USB
- ▶ Printer: Optional



# Alaska Prime H / Alaska Prime R Air Conditioning Service Units

## Air Conditioning Service Units

The new range of A/C service units, ALASKA PRIME and EVO, meets all the technical needs of professional service technicians for the maintenance and repair of air conditioning systems, including those on hybrid and electric vehicles.

The range consists of four models, ALASKA PRIME R for R134a gas, ALASKA PRIME H for HFO1234yf gas, and ALASKA EVO R for R134a gas and ALASKA EVO H for HFO1234yf gas.

The new ALASKA range includes a number of features specially designed to make A/C service more efficient, simple to use and friendly to the environment and surroundings.

**SECURE CHARGE:** It ensures that the A/C system is filled regardless of its capacity and ambient temperature.



Made in Italy



Made in Italy



## Key benefits

- ✓ Effective A/C system filling procedure, regardless of ambient temperature.
- ✓ USB interface for software updates and remote diagnostics.
- ✓ Ultra compact size, ideal as a mobile solution.
- ✓ Database with free biannual update

**SECURE CHARGE:** It ensures that the A/C system is filled regardless of its capacity and ambient temperature.

**VACUUM PUMP OIL REGENERATION:** The internal vacuum pump cleaning process has significantly extended the oil change intervals (up to 1000 hours), significantly reducing maintenance costs.

**ECO QUICK COUPLERS:** No refrigerant leaks thanks to the total recovery of the gas from hoses and quick connect fittings.

**AUTOMATIC CYLINDER VENTING:** Thanks to the automatic discharge of non-condensable gases, only pure refrigerant is contained in the inner cylinder

**REMOTE ASSISTANCE:** With Wi-Fi connectivity and Alaska MANAGER software, an authorized technician can take control of the device remotely and provide the right support or operation through a special function with a unique code generated by the device.

## FEATURES

- ▶ Safe fill | Reconditioning the vacuum pump oil
- ▶ LCD display
- ▶ Metal housing
- ▶ Built-in database with 2 year free upgrade
- ▶ Automatic Air Purge
- ▶ 2 oil tanks: (1 for new oil, 1 for used oil)
- ▶ Remote assistance (USB)

## SPECIFICATIONS

- ▶ Dimensions: 532 x 617 x 957 mm
- ▶ Weight 65 kg
- ▶ Cylinder capacity: 12 l
- ▶ OPTIONAL:

Eco quick couplers

Thermal printer for printing service reports

Service kit for hybrid and electric vehicles

Nitrogen leak test or hydrogen leak test kit

Gas Identifier

Dedicated database for agricultural and construction machinery (for Prime R only)

## Alaska Prime R | Alaska Prime H

Alaska Prime A/C service units offer a wide range of applications thanks to their compact dimensions and low weight.

With Alaska Prime R (R134a) and Alaska Prime H (R1234yf), you can achieve the highest level of service for your air-conditioning systems without major investment, while ensuring maximum environmental responsibility.

These units are characterised by a high level of precision and outstanding robustness, which, combined with their compact size, make them ideal for mobile use. Their operation is simple and intuitive, minimizing the risk of damage to the vehicle being operated or the unit itself. With an optional database dedicated to agricultural and construction machines, it is the ideal tool for mobile heavy equipment service. In this case, it may be helpful to use an additional service hose extension kit to connect in a variety of hard-to-reach areas.

alaska  
prime

# Alaska EVO H / Alaska EVO R Air Conditioning Service Units

## Air Conditioning Service Units

The new range of A/C service units, ALASKA PRIME and EVO, meets all the technical needs of professional service technicians for the maintenance and repair of air conditioning systems, including those on hybrid and electric vehicles.

The range consists of four models, ALASKA PRIME R for R134a gas, ALASKA PRIME H for HFO1234yf gas, and ALASKA EVO R for R134a gas and ALASKA EVO H for HFO1234yf gas.

The new ALASKA range includes a number of features specially designed to make A/C service more efficient, simple to use and friendly to the environment and surroundings.

**SECURE CHARGE:** It ensures that the A/C system is filled regardless of its capacity and ambient temperature.



Made in Italy



## Key benefits

- ✓ Effective A/C system filling procedure, regardless of ambient temperature.
- ✓ USB interface for software updates and remote diagnostics.
- ✓ Ultra compact size, ideal as a mobile solution.
- ✓ Database with a free 2-year update

alaska  
evo

- ✓ **SECURE CHARGE:** It ensures that the A/C system is filled regardless of its capacity and ambient temperature.
- ✓ **VACUUM PUMP OIL REGENERATION:** The internal vacuum pump cleaning process has significantly extended the oil change intervals (up to 1000 hours), significantly reducing maintenance costs.
- ✓ **ECO QUICK COUPLERS:** No refrigerant leaks thanks to the total recovery of the gas from hoses and quick connect fittings.
- ✓ **AUTOMATIC CYLINDER VENTING:** Thanks to the automatic discharge of non-condensable gases, only pure refrigerant is contained in the inner cylinder
- ✓ **REMOTE ASSISTANCE:** With Wi-Fi connectivity and Alaska **MANAGER** software, an authorized technician can take control of the device remotely and provide the right support or operation through a special function with a unique code generated by the device.



Made in Italy

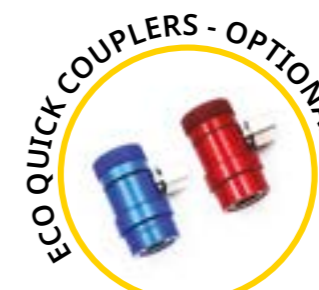

## FEATURES

- ▶ Safe fill | Reconditioning the vacuum pump oil
- ▶ 7" high resolution touch screen display
- ▶ One-Touch cover opening
- ▶ Built-in database
- ▶ Automatic Air Purge
- ▶ 2 oil containers: (1 for new oil, 1 for used oil)
- ▶ REMOTE ASSISTANCE - Wi-Fi

## SPECIFICATIONS

- ▶ Dimensions: 620 x 720 x 1090 mm
- ▶ Weight: 74 kg
- ▶ Cylinder capacity: 12 l
- ▶ OPTIONAL:

Eco quick couplers

Thermal printer for printing service reports

Service kit for hybrid and electric vehicles

Nitrogen leak test or hydrogen leak test kit

Gas Identifier

Dedicated database for agricultural and construction machinery (for EVO R only)

## Alaska EVO H | Alaska EVO R

Alaska Prime A/C service units offer a wide range of applications thanks to their compact dimensions and low weight

With Alaska Prime R (R134a) and Alaska Prime H (R1234yf), you can achieve the highest level of service for your air-conditioning systems without major investment, while ensuring maximum environmental responsibility.

These units are characterised by a high level of precision and outstanding robustness, which, combined with their compact size, make them ideal for mobile use. Their operation is simple and intuitive, minimizing the risk of damage to the vehicle being operated or the unit itself. With an optional database dedicated to agricultural and construction machines, it is the ideal tool for mobile heavy equipment service. In this case, it may be helpful to use an additional service hose extension kit to connect in a variety of hard-to-reach areas.

## Air Conditioning Service Units

|   | ALASKA PRIME R<br>(007936701000)                   | ALASKA PRIME H<br>(007936701010)                   | ALASKA EVO R<br>(007936701020)            | ALASKA EVO H<br>(007936701030)            |
|---|--|--|---|---|
| Gas type  | R134a  | R1234yf  | R134a                                     | R1234yf                                   |
| High performance vacuum pump  | 50 l/min , 0,02 mbar                               | 50 l/min , 0,02 mbar                               | 50 l/min , 0,02 mbar                      | 50 l/min , 0,02 mbar                      |
| Cylinder capacity   | 12 l   | 12 l   | 12 l                                      | 12 l                                      |
| Compressor displacement   | 8 cc   | 8 cc   | 14 cc                                     | 14 cc                                     |
| Dryer filter capacity (amount of recovered gas)   | 50 kg  | 50 kg  | 100 kg                                    | 100 kg                                    |
| Recovery  | >95%   | >95%   | >95%                                      | >95%                                      |
| Pressure sensors  | LP   | LP   | LP  | LP  |
| Oil containers  | 2 (new oil, used oil)                              | 2 (new oil, used oil)                              | 2 (new oil, used oil)                     | 2 (new oil, used oil)                     |
| Oil scales  | NONE   | NONE   | YES                                       | YES                                       |
| Operating temperature   | 10°C + 50°C  | 10°C + 50°C  | 10°C + 50°C                               | 10°C + 50°C                               |
| Power supply  | 230 V, 50 Hz, 800 W                                | 230 V, 50 Hz, 800 W                                | 230 V, 50 Hz, 800 W                       | 230 V, 50 Hz, 800 W                       |
| Hoses lenght  | 3 m  | 3 m  | 4,5 m                                     | 4,5 m                                     |
| Display   | black and white 35x200 mm<br>4 lines/30 characters | black and white 35x200 mm<br>4 lines/30 characters | 7" colour touch screen                    | 7" colour touch screen                    |
| Keyboard  | 4 arrow buttons, OK, ESC                           | 4 arrow buttons, OK, ESC                           | touch screen                              | touch screen                              |
| Menu languages  | 25   | 25   | 25  | 25  |
| Warranty  | 24 months  | 24 months  | 24 months                                 | 24 months                                 |
| Certificates  | CE, PED  | CE, PED  | CE, PED                                   | CE, PED                                   |
| Automatic air purge   | Automatic / manual valve                           | Automatically / manually<br>from the menu          | Automatically / manually<br>from the menu | Automatically / manually<br>from the menu |
| Service report printout   | USB (pdf)  | USB (pdf)  | Wi-Fi/e-mail/USB (pdf)                    | Wi-Fi/e-mail/USB (pdf)                    |
| Automatic refrigerant recovery and delivery   | ✓  | ✓  | ✓   | ✓   |
| Automatic oil recovery from the system  | ✓  | ✓  | ✓   | ✓   |
| Manual operation mode   | ✓  | ✓  | ✓   | ✓   |
| Automatic service hose compensation   | ✓  | ✓  | ✓   | ✓   |
| Secure Charge filling function  | ✓  | ✓  | ✓   | ✓   |
| Reconditioning the vacuum pump oil  | ✓  | ✓  | ✓   | ✓   |
| A/C performance test  | ✓  | ✓  | ✓   | ✓   |
| Cylinder pressure reading   | ✓  | ✓  | ✓   | ✓   |
| Wireless connectivity   | 007936701140 OPTIONAL<br>(BT)                      | 007936701140 OPTIONAL<br>(BT)                      |   |   |
| Hermetically sealed containers (Humidity Stop)  | 007936701240 OPTIONAL                              | 007936701240 OPTIONAL                              | 007936701240 OPTIONAL                     | 007936701240 OPTIONAL                     |
| Service hose extension kit - 3.5 m  | 007936701080 OPTIONAL                              | 007936701080 OPTIONAL                              | 007936701080 OPTIONAL                     | 007936701080 OPTIONAL                     |
| Eco quick couplers  | 007936701220 OPTIONAL                              | 007936701230 OPTIONAL                              | 007936701220 OPTIONAL                     | 007936701230 OPTIONAL                     |
| Gas Identifier  | 007936701170 OPTIONAL                              | 007936701170 OPTIONAL                              | 007936701180 OPTIONAL                     | 007936701180 OPTIONAL                     |
| Service kit for electric and hybrid vehicles  | 007936701110 OPTIONAL                              | 007936701110 OPTIONAL                              | 007936701100 OPTIONAL                     | 007936701100 OPTIONAL                     |
| Nitrogen leak testing kit without a detector  | 007936701200 OPTIONAL                              | NO   | 007936701200 OPTIONAL                     | NO  |
| Hydrogen leak detection kit   | 007936701090 OPTIONAL                              | 007936701090 OPTIONAL                              | 007936701090 OPTIONAL                     | 007936701090 OPTIONAL                     |
| USB/Wi-Fi/Bluetooth interface for remote diagnostics,<br>database and software updates. | 007950025880 OPTIONAL                              | 007950025880 OPTIONAL                              | 007950025880 OPTIONAL                     | 007950025880 OPTIONAL                     |
| Protective cover  | 007936701070 OPTIONAL                              | 007936701070 OPTIONAL                              | 007936701190 OPTIONAL                     | 007936701190 OPTIONAL                     |
| Thermal printer   | 007936701120 OPTIONAL                              | 007936701120 OPTIONAL                              | 007936701130 OPTIONAL                     | 007936701130 OPTIONAL                     |
| Thermal printer   | 007936701150 OPTIONAL                              | 007936701150 OPTIONAL                              | 007936701160 OPTIONAL                     | 007936701160 OPTIONAL                     |

# Alaska BUS R134a

## High-capacity air conditioning service station

ALASKA BUS is a fully automatic device from Magneti Marelli, designed for the diagnosis and servicing of large air conditioning systems. The database of passenger cars, vans, lorries and agricultural machinery streamlines the operator's work and speeds up servicing of air-conditioning systems. The station features a large tank and one of the most powerful vacuum pumps (226 l/min), making it ideal for working on large systems, such as those found in buses.

007950015220

Made in Italy

alaska  
BUS



### TECHNICAL SPECIFICATIONS

- ▶ Refrigerant: R-134a
- ▶ Built-in database
- ▶ Electronic scale: accuracy +/- 10 g
- ▶ Electronic scale for used oil
- ▶ Timed injection of fresh oil
- ▶ Temporary contrast injection
- ▶ Electronic pressure gauge: Class 2.5
- ▶ Tank capacity: 27.2 litres - 25 kg
- ▶ Compressor displacement: 14 cc - 500 rpm
- ▶ Vacuum pump: 13.7 m<sup>3</sup>/h, 3.5 CFM - 226 l/min
- ▶ Maximum vacuum: 0.05 mbar
- ▶ Cables: 5 m (extendable to 8 m)
- ▶ Pressure gauge indicating the pressure in the inner cylinder
- ▶ Refrigerant pressure lock
- ▶ Calibration weights included
- ▶ Heating band for a gas cylinder
- ▶ Thermal printer



### Key benefits

- ✓ A high-performance vacuum pump and compressor
- ✓ Large-capacity tank
- ✓ Heating belt
- ✓ Weight lock

|   |   |
|---|---|
| Filter ALASKA PRIME<br>007936701050   |    |
| USB Database Upgrade for ALASKA PRIME / Database AGRI<br>007936701070<br>USB Database Upgrade for ALASKA EVO (CARS) - online<br>007936701190<br>USB Database Upgrade AGRI for ALASKA EVO (only R) - USB<br>007936701200 |    |
| Alaska Prime / EVO extension cable set<br>007936701080  |    |
| Nitrogen tightness test kit<br>Alaska Prime / EVO<br>007936701090   |    |
| ALASKA EVO hybrid car service kit (includes tank and activation code)<br>007936701100<br>ALASKA PRIME hybrid car service kit (includes tank, activation code and cable connector)<br>007936701110                       |  |
| Bluetooth kit for ALASKA PRIME<br>007936701140  |  |
| Printer for ALASKA PRIME<br>007936701150<br>Printer for ALASKA EVO<br>007936701160  |  |
| Refrigerant ID to ALASKA PRIME<br>007936701170  |  |
| Coolant ID for ALASKA EVO<br>007936701180   |  |

|  |   |
|--|---|
| ECO quick coupler set for R134 Alaska Prime / EVO<br>007936701220<br>Sada rychlospojiek ECO dla R1234yf Alaska Prime / EVO<br>007936701230 |    |
| ECO quick coupler set for R1234yf Alaska Prime / EVO<br>007936701240   |    |
| Container with silicone cartridge in oil container (3 pcs)<br>007936701250   |    |
| Refrigerant ID filter<br>007936701620  |    |
| Universal vacuum pump oil 0,5L for all vacuum pumps<br>007935090600  |   |
| Universal vacuum pump oil 1L for all vacuum pumps<br>007950024880  |  |
| Filter drier for ALASKA EVO<br>007936701040  |  |
| Safety cover for ALASKA PRIME<br>007936701120  |  |
| Safety cover for ALASKA EVO<br>007936701130  |  |

|  |   |
|--|---|
| Heating Belt For Container 12,5 L Clima Tech Plus/Hd/Evo/ Top/Next/Alaska 007935090760<br>Heating Belt For Container 27,2 L Clima Tech Plus/Hd/Evo/Top/ Next/Alaska 007935090770   |    |
| Printer For Station Evolution Plus/Hd/Next/Alaska Start<br>007935096320<br>Printer For Station Alaska Start HFO/Alaska BUS<br>007950015510   |    |
| Mm6F / Mm7F Service Kit (Filter+Oil)<br>007950024110<br>Air Check / Clima Tech / Next Service Kit (Filter+Oil)(Suitable for all AC Machines Magneti Marelli+Bosch ACS 500,450,400,Silvertronic,Tronic, Delphi-series Refmatic)<br>007950024130 |    |
| Vacuum Pump Oil 0,5 l For Diffrent Air Conditioning Stations 007935090600<br>Vacuum Pump Oil 1,0 l For Diffrent Air Conditioning Stations 007950024880<br>Vacuum pump oil 5 l, general purpose for all vacuum pumps 007950026580               |    |
| 12-month service extension on all A/C service units (up to 1 week after purchase)<br>099994910040  |  |
| 2023/2024 Book Database<br>007935090895  |  |
| USB Database Upgrade for Ct Top Next/Ct Top Maxi 2023<br>007935090891  |  |
| Station Database Upgrade for Clima Tech Mobile/ Evolution/Alaska Start 2023 - Memory Card<br>007935090870  |  |
| New Oil Or Uv Container For Clima Tech Plus / Hd / Evo/ Top / Next 007935096230<br>Oil drain container for Clima Tech Plus/Hd/Evo (not fot CT Top Next) 007935097100   |  |
| Gas analyser for the Alaska Start HFO/Alaska Premium HFO air conditioning service station<br>007950015690  |  |

|  |   |
|--|---|
| Oil Drain Container for Matic/Plus old series/Mobile (round)<br>007950013570   |    |
| Used oil container for Clima Tech Top/Plus/HD Next/Alaska (hard plastic)<br>007935090915<br>007935096770   |    |
| Kit For Covering Hybrid Cars For Clima Tech Plus/Hd Next<br>007935090835   |    |
| Additional Set For A/C Flushing For A/C Machines<br>007950024060   |   |
| Refrigerant recovery device with oil separator 134a / R1234yf and others<br>007936211345   |  |
| <ul style="list-style-type: none"> <li>- recovery up to 6 kg / min! high efficiency and fast recovery process</li> <li>- work on all refrigerants and oil separation</li> <li>- reliable ball valves, handy and light</li> <li>- Cat.III: R-1 2, R-1 34a, R-401C, R-406A, R-500, HFO-1 234yf</li> <li>- Cat IV refrigerants: R-22, R-401A, R-401 B, R-402B, R-407C, R-407D, R-408A, R-409A, R-41 1A, R-41 1B, R-41 2A, R-502, R-509 Cat V: R-402A, R-404A, R-407A, R-407B, R-410A, R-507, R32</li> <li>- Voltage 220-240 VAC 50/60 Hz 1 10-1 27 VAC 60 Hz 100 VAC 50/60 Hz 1 10/220 VAC 50/60 Hz,</li> <li>- Compressor 1/2 HP oil-free, maximum current 4A 50Hz, 8A 60Hz,</li> <li>- 38 bar / 550 psi high pressure switch</li> <li>- Angle. III Cat. IV Cat. V</li> <li>- Recovery capacity Steam 0.23 kg / min 0.25 kg / min 0.26 kg / min</li> <li>- Liquid 1.57 kg / min 1.81 kg / min 1.85 kg / min</li> <li>- Push / Pull 4.64 kg / min 5.57 kg / min 6.22 kg / min</li> <li>- Optional low pressure switch</li> <li>- Working temperature 0-40 ° C</li> <li>- Housing impact-resistant polyethylene blow molded</li> <li>- Dimensions 485 mm long x 220 mm wide x 365 mm high</li> </ul> |   |

## ACCHECK600 A/C compressor test bench

007935013900

**Adapter kit  
for ACCHECK600  
additional kit contains 38 cables  
and adapters**

007935013910



### Diagnostic station for automotive air conditioning compressors

The ACCHECK600 test station is designed for diagnosing electric air conditioning compressors in hybrid and electric vehicles. Diagnostics on all types of 12/24V belt-driven vehicle compressors. The testing process is automated: simply secure the compressor, connect the cables and adapters and then start the test. The station will detect potential problems and measure compressor performance and functionality. Compressed nitrogen is used as the working medium.

#### ADVANTAGES:

- Easy connection of the compressor with special cables and fittings;
- The compressor test takes no longer than two minutes;
- Nitrogen is safe for the environment;
- Simple, intuitive control panel menu;
- The automatic diagnostic mode includes:
  - checking for short circuits in the low voltage system and high voltage parts of the inverter;
  - measuring the compressor performance and comparing it with a reference value from the database;
- Free software updates

| Main                                   |  |
|--|--|
| Supply voltage, V                      | 400  |
| Mains type                             | Three-phase  |
| Drive power, kW                        | 5.5  |
| Dimensions (LxWxH), mm                 | 900x570x1280   |
| Weight, kg                             | 183  |
| Refrigerant used                       | R134a, R1234yf   |
| Refrigerant filtration                 | Yes (1 µm2)  |
| Amount of refrigerant in the system, g | R134a - 1100, R1234yf - 1050   |
| Station complement                     | External station   |
| Type of refill guns                    | Car HP or LP   |
| Oil used                               | PAG46yf  |
| Quantity of oil in the system, g       | 200  |
| Compressor test                        |  |
| Rated voltage of tested units, V       | 12, 24   |
| Drive speed, rpm                       | od 0 do 3000   |
| Drive speed control                    | Stepless/stepwise  |
| Compressor drive type                  | V-belt/multi-v-belt  |
| Device bus vacuum                      | Yes  |
| Refrigerant evacuation from the unit   | Yes  |
| Output parameters                      | HP, bar; LP, bar; Tcompressor, °C; T evaporator, °C; Pulse width modulation %. |
| Additionally                           |  |
| Printing results                       | Yes  |
| Software update                        | Yes  |
| Saving diagnostic results              | Yes  |
| Connecting peripheral devices          | 2 x USB 2.0  |
| Internet connection                    | Ethernet, Wi-Fi (802.11 a/b/g/ac)  |

## ACCHECK500 Test bench for electric air conditioning compressors

007935013920

**Adapter kit for ACCHECK500  
44 adapters/wires included**

H-series (voltage) cables - 17 pcs.

D-series (information) cables - 15 pcs.

Adapters (HP - high pressure; LP - low pressure) - 12 pcs.

007935013930

### Diagnostic station for automotive air conditioning electrical compressors

#### CAPACITIES:

- Allows testing of compressors with an operating range of 200 V to 400 V DC
- Electromagnetic diagnosis of the clutch and control valves, whether assembled with the compressor or separately from it;
- Start-up and test of regenerated compressors;
- Pre-sales check of new compressors-analogue;
- Generation and printing of a test report on an external printer.

#### ADVANTAGES:

- Test bench operation on refrigerants R134 or R1234yf;
- Two diagnostic modes: automatic and manual;
- User-friendly and intuitive touch screen menu;
- Free automatic firmware update;
- Ability to record and print diagnostic results;



A kit of data cables (Figure 1) and power cables (Figure 2) optional



Figure 1



Figure 2

| Main                   |              |
|------------------------|--------------|
| Supply voltage, V      | 230          |
| Mains type             | Single-phase |
| Mains frequency, Hz    | 50/60        |
| Power consumption, kW  | 3            |
| Dimensions (LxWxH), mm | 740x600x550  |
| Weight, kg             | 40           |

### Kit - The equipment supply kit includes:

| Name   | Number, pcs.  |
|--|---|
| ACCHECK500 station                               | 1   |
| Kit of data and power cables - 8 pieces included | 8   |
| Station operation kit                            | 1   |
| User manual                                      | 1   |
| Compressors tested                               |   |
| Equipment tested                                 | With 2-pin high-voltage connector. (Units with integrated inverter) |
| Supply voltage of tested devices, V              | 200 to 400  |
| Working gas                                      | Compressed nitrogen (external source)                               |
| Operating pressure of nitrogen source            | 6.8 Bar (90..110 psi)   |
| Nitrogen consumption                             | 100 l/one test  |
| Nitrogen recovery                                | No, the exhaust gases are discharged into the atmosphere            |
| Nitrogen connection                              | SAE 1/4"  |
| Additional                                       |   |
| Software update                                  | Yes   |
| Internet connection                              | Ethernet  |
| Connecting a flash drive                         | USB Type-C  |

**Wigam CTR Ø76mm filter, length 230mm, connections 1/4 x 1/4" SCREW IN**  
007950025065

**Part no:**  
XH-412 14015013 (Wigam), FG302, 0707764052, XH412, 14015013  
**A.** Length: 230 mm  
**B.** Diameter: Ø 76 mm  
**C. D. E.** Connections: 1/4" x 1/4" SAE SCREW IN  
Weight: 1 kg

**Compatible with:**  
BEHR SECU-MAX 19, SECU-MOBILE, SECU-SMART (2 filters), CTR Kheos, Kheos Plus, Logika, Mixer134, Pratika, Pratika Bus(3 filters) FOG AC Nano+WIGAM AMICA, PICCOLA, EASYREC 120R,150, WÜRTH WAC 2000, Coolius 1000, Coolius 2000.



**CHEAPER AS A SET!**  
Service set (filter+oil+foam) for station MM6F/MM7F  
007950024110

**Filter for Oksys, Air Solutions, Starline Ø60mm, length 160mm, connections 1/4 x 1/4" SCREW IN**  
007950025925

**Part no:**  
Nr OKSYS : FLT002;Parker / Sporlan WEU162FC; Air Solutions: Totaline D162;  
**Parameters:**  
**A.** Length: 160 mm  
**B.** Diameter: Ø 60 mm  
**C. D.** Connections: 1/4" x 1/4" SAE SCREW IN  
Weight: 0,7 kg

**Compatible with:**  
Oksys, Air Solutions, Starline Air Solutions KK3 (R1234yf), AXIA (R134a), GLX134 (R134a), KK2 (R134a), X2 (R34a), K1 (R34a) Oksys Agricol 300, 300YF, FK2200, FK2200YF, ECOS150, ECOS200 R134a (FKE200), ECOS200YF R1234YF (FKE200YF), ECOS300 R134a, ECOS300YF R1234YF, FAST200 FAST200YF, FAST202, FAST222YF, FAST300, FAST300YF, FAST320, FAST320YF, FAST340, FAST340YF, Starline Handy; Handy Plus2; Clever; Clever Plus; Clever Plus2; Dual Gas; Dual Plus; Country Grubber OFF ROAD, 2 GAS Invento HANDY; HANDY AGRI; ADVANCE BUS; ADVANCE DUAL



**CHEAPER AS A SET!**  
Service set (filter+oil+foam) 007950024130

**Filter for BrainBee/Valeo Ø76 mm, length 243mm, connections 3/8 "x 3/8" SCREW IN**  
007950025920

**Part no:**  
Robinair 34724 (RA-34724, RA34724), BrainBee 1010350034XX et Danfoss : DCL 303 / 023Z3049, DML 303  
**Parameters:**  
**A.** Length: 243 mm  
**B.** Diameter: Ø 76 mm  
**C. D.** Connections: 3/8" x 3/8" SAE SCREW IN  
Weight: 0,7 kg

**Compatible with:**  
- BrainBee Clima 8000; Clima 8250; Clima 8500; Clima 9000; Clima Multigas; Clima 1234 HFO  
- Valeo CLIM FILL PROFIL; CLIM FILL MAXI  
- Ecotechnics ECK BUS PRO, ECK BUS PRO-N2 (as a second filter)  
The CLIMA6000 and CLIMA9000 P BUS EVO A/C charging stations use an additional filter drier.



**Robinair Spx Valeo Bosch Ø90 filter, length 294mm, connections 1/4" x 1/4" OR**  
007950025060

**Part no:**  
5117399 (Robinair), WEU412MOI ou LN1132 (Parker Worldseries) PLD412.1T WEU412MOI, FGC402, SP00100001(Bosch)  
**Parameters:**  
**A.** Length: 294 mm  
**B.** Diameter: Ø 90 mm  
**C. D.** Connections: 1/4" x 1/4" SAE OR  
Weight: 1 kg

**Compatible with:**  
Valeo ClimFill - Auto/Advance, AC500, AC650, AC650 PRO Bosch ACS 611, 652, 810,650 Robinair AC400, AC500, AC600, AC650, AC500Pro, AC590 Pro, AC690 Pro, AC790 Pro BEM Muller Ecolid 6620, Ecolid 6720 Tecnotest Ecolid 6620, Ecolid 6720



**Filter for Magneti Marelli, Bosch, Delphi Ø60mm, length 207mm, connections 3/8 x 3/8" OR**  
007950025075

**Part no:**  
XH-412 14015013 (Wigam), FG302, 0707764052, XH412, 14015013  
**Parameters:**  
**A.** Length: 207mm  
**B.** Diameter: Ø 60 mm  
**C. D.** Connections: 3/8" x 3/8" SAE OR  
Weight: 0,7 kg

**Compatible with:**  
Bosch ISC Tronic model 0028; Tronic model 0028 Marelli MM7F Refmatic Plus (AT41502)



**Filter for Magneti Marelli, Bosch, Delphi Ø 76mm, length 230mm, connections 3/8 x 3/8" SAE OR**  
007950025055

**Part no:**  
ISC : 7108000200 Parker: PLD163MOI/FG 303 OR  
**Parameters:**  
**A.** Length: 230 mm  
**B.** Diameter: Ø 76 mm  
**C. D.** Connections: 3/8" x 3/8" SAE OR  
Weight: 0,7 kg

**Compatible with:**  
Bosch: ACS 400, ACS 450, ACS 500, ACS 600, Silvertronic, Tronic; Delphi Refmatic- SPX: 6635-AD Magneti Marelli Air Check Plus, Air Check HD, Air Check Matic, Clima Tech Plus, Clima Tech Mobile, Clima Tech TOP, Clima Tech HD, Clima Tech TOP HFO, Alaska Start, Alaska Start HFO, Alaska Start BUS, Alaska Start PREMIUM, Alaska Start PREMIUM HFO ISC SliverDiag, ISC Futura, ISC Tronic Business Invento Acix Advance



**Robinair Spx Valeo Bosch Ø76mm filter, length 275mm, connections 1-1/2"-12UNF-2A**  
007950025050

**Part no:**  
Bosch: S P01 100 355 (SP01100355) Robinair: RA34724 Bosch: SP01100094 Robinair: 541619; DCY82213; FLT5510, FLT5512, DM400-7, 832102, 070344-05-WX  
**Parameters:**  
**A.** Length: 275 mm  
**B.** Diameter: Ø 76 mm  
**C.** Przyłącze: 1-1/2"-12UNF-2A SAE  
Weight: 1 kg

**Compatible with:**  
Bosch ACS752, ACS663, 663-P, 653-P, 563, 563 P, 863, 763, 753, ACS661-G (1234YF). Not suitable for the Bosch ACS-651 (because it is too long). Actia Muller 1700; ECK4000 PSA; ACM3400-HFC (R134a), Actia Luller ACM3400-HFO (R1234yf), Actia Luller, ACM3400-2GP (R134a & R1234yf), (2 filters needed) Ecotechnics ECK3500/3900 PRO, 3900 HFO; ECK3000; ECK Twin Pro; ECK4000/VDA/HFO; ECK FLAG; ECK FLAG 110V; ECK4012, ECK TWIN 12, ECK TWIN PRO Robinair X34701/34700/34701/34704 (gas 134a); Robinair 17700A/17701A (gas R12) séries 17700-2K Robinair 34131A, 34134-2K, 342000, 34234 (ESCREW IN Charge), 34288,345002K 34700 (manufactured after March 1998), 34700 (manufactured after s/jn 4000 1998), 347002K, 34700Z, 34702Z, 34788, 34800 (2 filters), 348002K (2 filters), 34900, 34988 Robinair AC1234-3i/5i/7i/8i, AC1234-X YF, AC500, AC788, Cool-Tech 34988, Tecnotest Ecolid 6310BEPCO ECO300DPA (Ecotechnics), Snap-On EEAC325A



**Texa Robinair Ø 76mm filter, length 240mm, connections 3/8" x 3/8" OR**  
007950025070

**Part no:**  
TEXA 42801002 Bosch SP00101192 Parker WEU303MOI Waeco 44404000098  
**Parameters:**  
**A.** Length: 240 mm  
**B.** Diameter: Ø 76 mm  
**C. D.** Connections: 3/8" x 3/8" SAE OR  
Weight: 1 kg

**Compatible with:**  
Robinair: ACM3000, Robinair AC595PRO, AC1234-3 et AC1x34-3; Air 690 Pro; Bosch: ACS 561, ACS 661, ACS 511,1234-3, AC 595 Texa: Konfort K650E, K670E, 705R,712R, 720,760 6xx,seria 7xxx PROFITool ACM3000, ATT, Top Automotive, WAECO ASC 1000, ASC 2000, ASC 2000RPA, ASC 3000 Waeco RHS-1050, ASC 3000



**Filter for Texa Robinair/Bosch Ø76mm, length 235mm, connections 3/8"x M3/8"OR**  
007950025560

**Part no:**  
Parker WEU303MOI, SP00101192 (Bosch)  
**Parameters:**  
**A.** Length: 235 mm  
**B.** Diameter: Ø 76 mm  
**C. D.** Connections: 3/8" x 3/8" SAE OR  
Weight: 1 kg

**Compatible with:**  
Johnson Controls Alize X9, Alize X10, Alize X20, Alize X30, Robinair: ACM3000, Robinair AC595PRO, AC1234-3 et AC1x34-3 ; Air 690 Pro Delphi Refmatic- SPX: 6635-AD



**Bosch filter 1-3/8"-12UNF-2A for ACS 651 and 751 Ø76mm, length 213mm, connection 1-3/8"-12UNF-2A**  
007950027610

**Part no:**  
F002DG1534  
**Parameters:**  
**A.** Length: 213 mm  
**B.** Diameter: Ø 76 mm  
**C.** Connections: 1-3/8"-12UNF-2A  
Weight: 1 kg



**Filter for Alaska EVO Ø 58mm length 224mm, connections 1/4"x1/4" SCREW IN**  
007936701040

**Part no:**  
DML -302; C.FO.302.S-FH  
**Parameters:**  
**A.** Length: 224x mm  
**B.** Diameter: Ø 67 mm  
**C. E.** Connections: 1/4" x 1/4" SAE SCREW IN  
Weight: 1 kg

**Compatible with:**  
Magneti Marelli Alaska EVO, Alaska EVO, Alaska HFO Brain Bee Air Nex 9450, 9350 Mahle ACX410, 350, 480 ArticPro seria x50, x80



**Filter for BrainBee, Krios, Spin Ø76mm, length 160mm, connections 1/4" x 1/4" OR**  
007950025930

**Part no:**  
FTCS15007AGV, NDP25CR, OAA025CR000, 023Z5042, Parker WEU162F, Danfoss DML162, DCL 162  
**Parameters:**  
**A.** Length: 160 mm  
**B.** Diameter: Ø 76 mm  
**C. D.** Connections: 1/4" x 1/4" SAE SCREW IN  
Weight: 0,7 kg

**Compatible with:**  
BrainBee CLIMA 6000, 6000 EVO, Valeo CLIMA FILL EASY EcoTechnics ECK 1800, 1800-HFO, 1890,1890-HFO, ECK2500, ECK5500K, ECK6500K, NEXT, ECK BUS, BUS PRO-N2:ECK-LAND; ECK 800 CINQUECENTO, VA, CINQUECENTO HFO, VA, CINQUECENTO PRO, CINQUECENTO 12, ECK NEXT 2019, 2020,2020 110V, NEXT PRO, NEXT PRO HYBRID; ECK 1900-PREMIUM, 1900-PRO, 1900 PRO HYBRID, 1900-PREMIUM 100V  
Four Seasons EuroMaxx, Spin Breeze Touch Dual X4; Breeze Advance Dual, Evo, Plus, Bus; Astrabus Advance R134a, Mutigas; Clever Miura X, M, B; Clever Advance Plus, Basic; Country Clima Advance 220V, BIOPower INVENTO Handy Advance, INVENTO Handy X R1234yf Profitool FACOM AC.200;AC.182; FOG AC.184 MotorX (model 163) Johnson Controls Eole X4, Eole X6, Eole X7, Eole X9,



**Waeco ASC/ASC-G - ALUMINUM Ø 67mm filter, length 275mm, connections 1-3/8"-12UNF-2A**  
007950027605

**Part no:**  
WAECO 4440400009; 4445900221  
**Parameters:**  
**A.** Length: 230 mm  
**B.** Diameter: Ø 76 mm  
**C. D. E.** Connections: 1-3/8"-12UNF-2A  
Weight: 1 kg

**Compatible with:**  
ASC 5000 RPA, 1100,1300G, 2000G, 2300G, 2500 G, 3300G, 3500G, 5100G, 5300G, 5500G, 6100G, 6300G, RHS-950; 1050



**Filter for Brain Bee/Mahle/Alaska Prime Ø 76mm length 167mm, connections 3/8"x3/8" SCREW IN**  
007936701050

**Part no:**  
DML 163  
**Parameters:**  
**A.** Length: 167 mm  
**B.** Diameter: Ø 76 mm  
**C. D. E.** Connections: 3/8" x 3/8" SAE SCREW IN  
Weight: 0,7 kg

**Compatible with:**  
BrainBee Clima 6000, 6000 Easy, 6000Plus, 6000 ECO 1234 Alaska Prime, Prime HFO, FTTECH (EFRA) 6000 PLUS FTT FTTECH (EFRA) 6000 ECO FTT 1234, Valeo ClimFill Easy AVL Ditest ADS 110 R134a, Air nex 9310, 9320 Mahle ACX410, 310, ArticPro seria x20x10



| Code         | Length | Diameter | Connections   | Part number   |
|--------------|--------|----------|---|---|
| 007950025065 | 230 mm | Ø76 mm   | 1/4" x 1/4" SAE SCREW IN  | XH-412 14015013 (Wigam), FG302, 0707764052, XH412, 14015013   |
| 007950025075 | 207 mm | Ø60 mm   | 3/8X3/8 SAE OR  |   |
| 007950025925 | 160 mm | Ø60 mm   | 1/4" x 1/4" SAE SCREW IN  | Nr OKSYS: FLT002; Parker / Sporlan WEU162FC; Air Solutions: Totaline D162;  |
| 007950025055 | 230 mm | Ø76 mm   | 3/8" x 3/8" SAE OR  | Bosch: S P01 100 355 (SP01100355) Robinair: RA34724 Bosch: SP01100094 Robinair: 541619; DCY82213; FLT5510, FLT5512, DM400-7, 832102, 070344-05-WX |
| 007950025920 | 243 mm | Ø76 mm   | 3/8" x 3/8" SAE OR  | Robinair 34724 (RA-34724, RA34724), BrainBee 1010350034XX et Danfoss : DCL 303 / 023Z3049,  |
| 007950025050 | 275mm  | Ø76 mm   | 1-1/2"-12UNF-2A   | Bosch: S P01 100 355 (SP01100355) Robinair: RA34724 Bosch: SP01100094 Robinair: 541619; DCY82213; FLT5510, FLT5512, DM400-7, 832102, 070344-05-WX |
| 007950025060 | 294mm  | Ø90 mm   | 1/4" X 1/4" SAE OR  | 5117399 (Robinair), WEU412MOI ou LN1132 (Parker Worldseries) PLD412.1T WEU412MOI, FGC402, SP00100001(Bosch)                                       |
| 007950025070 | 240 mm | Ø76 mm   | 3/8" x 3/8" SAE OR  | TEXA 42801002 Bosch SP00101192 Parker WEU303MOI Waeco 44404000098   |
| 007950025560 | 235 mm | Ø76 mm   | 3/8" x 3/8" SAE OR  | Parker WEU303MOI, SP00101192 (Bosch)  |
| 007950025930 | 160 mm | Ø76 mm   | 1/4" x 1/4" SAE OR  | FTCS15007AGV, NDP25CR, OAA025CR000, 023Z5042, Parker WEU162F, Danfoss DML162, DCL 162   |
| 007950027610 | 213 mm | Ø76 mm   | 1-3/8"-12UNF-2A   | F002DG1534  |
| 007950027605 | 275 mm | Ø67 mm   | IN 13,7x3,5 mm/11,7x8,0 mm/ 10,0x6,9 mm D 9,02 mm E.OUT 10,6x3,4 mm/8,6x5,7mm/7,0x10,2 mm | WAECO 4440400009; 4445900221  |
| 007936701050 | 224 mm | Ø58 mm   | 1/4" x 1/4" SAE OR  | DML -302 ; C.FO.302.S-FH  |
| 007936701040 | 167 mm | Ø76 mm   | 3/8" x 3/8" SAE SCREW IN  | DML 163   |

**Do you also need oil for your vacuum pump?**



**Vacuum pump oil 500 ml universal for all vacuum pumps**  
007935090600



**Vacuum pump oil 1000 ml universal for all vacuum pumps**  
007950024880



**Vacuum pump oil 5000 ml universal for all vacuum pumps**  
007950026580

# REFPRO 5.0

Portable 1234yf / r134a refrigerant analyser with integrated printer

007936211470



[www.wyposazeniemm.pl](http://www.wyposazeniemm.pl)

COMPLIES WITH J2912

LEGIBLE PRINTOUT

FAST AND ACCURATE DIAGNOSIS



Portable 1234yf / r134a refrigerant analyser with integrated printer.

007936211470

The REFPRO 5.0 refrigerant analyser uses state-of-the-art infrared (NDIR) technology to provide rapid refrigerant analysis. Designed for accurate analysis of 1234yf and r134a, this equipment can identify R-1234yf, R-134a, HC, moisture and air as contaminants. It even detects dangerous illegal substitutions and mixtures, including propane and butane.

#### TECHNICAL DATA:

- 4,3-inch colour touch screen,
- 230V/12V power supply
- thermal printer,
- internal rinsing chamber,
- information about the type of gas
- information on the percentage of gases
- power cables the set contains: carrying case

- connector for r134a refrigerant
- quick-connect coupling for replacing gas connectors
- manual
- Quick and accurate determination of refrigerant purity
- Display of percentage concentration of R1234Yf, R134a, R22 and hydrocarbons
- Improved oil resistance (replaceable oil restrictor)

#### SPECIFICATION:

- Refrigerants tested: R1234yf, R134a
- Accuracy better than (+/-) 1.0%
- Displayed percentage concentration: R1234yf, R134a HC
- Temperature range: 10°C to 50°C
- 230V/12V power supply (battery terminals)
- the set contains: carrying case
- Communication protocols: USB 2.0
- User interface: LCD + 3 buttons
- Certifications: CE, SAE
- Integral calibration pump: YES
- Oil contamination: Replaceable oil restrictor



# Ozonmaker MARELLI M-MX

007922112314 (FORMERLY MX4000 old code: 007936210010)

Highest ozone production efficiency, confirmed by long experience!



[www.wyposazeniemm.pl](http://www.wyposazeniemm.pl)



2-YEAR WARRANTY

MADE IN EU

Approved as a biocidal device

MAGNETI MARELLI

4000 mg/h

Ozonmaker M-MX - ozone production device

007922112314

By ionising the atmospheric air, the MARELLI M-MX device produces an unstable allotropic form of oxygen – ozone O<sub>3</sub>. Ozone, as a very strong oxidiser, removes all contaminations from the cabin. It removes residual water collecting on the floor covering and A/C system evaporator. It also eliminates unpleasant odours as well as fungi, bacteria and viruses dangerous to our health. Due to its high level of efficiency – over 4000 mg/h – the device works well for buses and larger vehicle cabins, it also enables much quicker decontamination of passenger cars. Ozone (O<sub>3</sub>) is a part of atmospheric air, generated as an effect of ultraviolet radiation. Ozone is heavier than air, unstable and quickly decomposing. The decomposition process contributes to the increase of air temperature, humidity and pollution. Ozone decomposes in water quicker than in the air. In its gaseous form, ozone is transparent, with a blue tint in thicker layers. Liquid ozone is dark blue, solid state – nearly black. Ozone is very strong oxidant, much more potent than regular oxygen.

- Ozone generator efficiency: 4000 mg/h
- External pump capacity: 10-15 l/min
- Programmable counter states: 1-60 min
- Pressure generated by the pump: 17 Kpa
- Working environment: inside well-ventilated rooms without corrosive gases
- Atmospheric operation conditions: 100±4 Kpa
- Operating temperature range: 5-40 °C
- Operating relative humidity: <80%
- Ozone generation method: corona discharges
- Outlet conduit diameter: 8 mm
- Power supply: AC 220-240V 50Hz

# BACTOBAN

007936211125 ultrasonic disinfection device

**Bactoban** - an innovative device for cleaning air-conditioning systems in passenger cars, agricultural machines, construction machines and trucks with the use of chemical substances.

**BACTOBAN** is an efficient ultrasonic device for refreshing air-conditioning systems and vehicle interiors, designed to use ultrasound to break down a dedicated disinfectant liquid to vapour with particles from 2 to 3 microns.

**PARAMETERS:**

- Supply voltage 230 V
- Capacity >300 ml/h
- Operating temperature 5 °C - 55 °C
- Particle diameter 2-3 µm
- Sound signalling for processes
- Control panel
- Overheating protection
- Low liquid level protection
- Possibility to use all liquids available on the market

|                 |                                |
|-----------------|--------------------------------|
| <b>230 V</b>    | OVERHEATING PROTECTION         |
| <b>300 ml/h</b> | SOUND SIGNALLING FOR PROCESSES |
| <b>5-55 °C</b>  | CONTROL PANEL                  |
| <b>2-3 µm</b>   | <b>1,5 kg</b>                  |



**INCLUDED IN THE KIT:**

- Fungus removal device
- Exhaust chimney
- Equipment
- Power cord
- Warranty 24 months
- Operating instructions
- Packaging
- CE declaration

A set of Refreshing Liquides for an ultrasonic device - 3 fragrances- 12 pcs (4 pcs each)  
007950026530

Refreshing Liquide for Ultrasonic Device - „Pine” - 250ml - 12pcs  
007950025350

Refreshing Liquide for Ultrasonic Device - „Lavenda” - 250ml - 12pcs  
007950025360

Refreshing Liquide for Ultrasonic Device - „Musk” - 250ml - 12pcs  
007950025370



Set Of 2 Decontamination Sprays 100 ml Foam and 150 ml “Granate”  
007950024870



The Magneti Marelli refreshing spray is a guarantee of a fresh smell and hygienic and clean car cabin. The disposable “grenade” is used to quickly remove bacteria, fungi and refresh the smell in the cabin.

Decontamination Spray - Singel-Use “Granate” 200 ml Lavenda  
007950024020

Decontamination Spray - Singel-Use “Granate” 200 ml Pine  
007950024021

Decontamination Spray - Singel-Use “Granate” 200 ml Musk  
007950024022

Decontamination Spray - Singel-Use “Granate” 200 ml Podwer  
007950026510

Decontamination Spray - Singel-Use “Granate” 200 ml Vanilla  
007950026520



Refreshing liquid 5000 ml  
007950025150



Cleaning Spray For Condenser 400 ml (2 pieces)  
007950024050



Fluid For Ultrasonic Nebulizer - Universal 1 l  
007950025490



Fluid For Ultrasonic Nebulizer - Universal 5 l  
007950025500



Concentrate for refreshing - 1000 ml  
007950025160



Cleaning Liquid For Evaporators 5 l  
007950025170



Cleaning Liquid For A/C System Elements (Active Foam) 1 l  
007950025180



Antibacterial refreshing spray 400 ml with dispensing tube (reusable)  
007950024900



Decontamination Foam 400 ml  
007950025630



R134A Gas Analyzer  
007935090940



**MINI ID - R134a REFRIGERANT ANALYZER:**

At the moment on the automotive market there is refrigerant. To prevent damage to the air conditioning system in your car or station air conditioning maintenance, control of quality factor. Mini ID is able to verify the quality of R134a refrigerant for air too much content as well as propane or butane pollution.

**SPECIFICATIONS:**

- Weight: 0.8kg
- Supported factors: R134a (Tetrafluoroethane)
- Tolerance: Correct / Incorrect - 95% Pure R134a
- Certificates: SAE J1771 and CE
- User Interface: Membrane buttons with indicator lamps
- The calibration method: Manual pump
- Storage temperature: -10°C to + 50°C
- Operating temperature: + 10°C to + 45°C

Pirometer/Laser Thermometer  
007950013810



Professional device for measuring the temperature of objects moving, inaccessible or dangerous to the touch. The pyrometer is equipped with a laser sight, precisely defining the place of measurement, has a high accurate to within 0.1°C. Allows for 15 hours continuous operation.

Electronic Scale 80 kg

007950025380

Max load 80 kg Electronic LCD screen wit accuracy 10 g. Packed in robust and quality plastic suitcase.



Spring Lock Tool HP hose for Toyota  
007950025030



Additional Filter  
007950013800



Condenser Fuse Comb  
007950025040



Digital Termomete  
007950024030  
• temperature range -50°C to +300°C



Dual Infrared Thermometer / Contact  
007950013830



Accurate thermometers, necessary in diagnosing systems C - laser thermometer, thermometer with probe or infrared digital thermometer.

Device filter Refpro/Ultima/Refpro 5.0  
007935020020  
Thermal paper for Ultima analyzers  
007935020030



GAS ID R1234yf:  
007935021060

Every professional car workshop equipped with this type of identifier is protected against the consequences of using the wrong refrigerant, i.e. damage to the A/C system or A/C service station. Some A/C systems and A/C service stations are equipped with appropriate detectors verifying the correctness of the refrigerant and it is also possible to use a hand-held identifier, via a USB connection, to verify the correctness of the refrigerant supplied. In practice, however, it is better to use an external detector in order to avoid contamination or damage to the system as a result of supplying the wrong refrigerant or the one contaminated with substances of unknown origin.

- Přesnost měření: (+/-) 1,0 %
- Přípustná čistota chladiva: 98 %
- Chladivo R1234yf, 5 kg (007950014325), souprava s 007950014561
- Vyměnitelná láhev pro vícenásobné použití, 12 kg

TECHNICAL DATA:  
• Detected refrigerant: R1234yf  
• Measurement accuracy: 95%  
• Power supply: 12V DC • Operating temperature: 10-45°C  
• Sample factor in pure form without oil • Inlet pressure: 1.38Bar - 20.70 bar



O-Rings Holder  
007950024820



Ford Kit Springlock 4 Pieces  
007950024760



Oil Injector 1/4" Ffl X 1/4" Mfl  
007950014140



Octagonal Wrench For Lp R134A Socket Remove  
007950014150



Octagonal Wrench For Hp R134A Socket Remove  
007950014160



# MM AC Guard

## 007936210780

**PROFESSIONAL, INDISPENSABLE, EASY TO USE  
PREVENTS PROBLEMS WITH HFO POLYMERISATION**

HFOs are the fourth-generation refrigerant gases most widely used in recent years in the automotive market and beyond. R1234YF is successfully used in all newly installed air conditioning systems from 2017 onwards due to its environmentally friendly properties and high efficiency. Recently, however, it has caused a lot of problems for technicians in the industry. There have been several reported cases of polymerisation of R1234YF gas, a phenomenon that can lead to extensive damage to the air conditioning system as well as the service stations themselves. The damage in some cases is irreversible as can be seen in the attached photos. The gas takes a solid form that can only be removed mechanically.

**PROTECT YOUR SERVICE EQUIPMENT AND FACILITIES**

by means of a special kit that allows simultaneous filtration and observation of the recovered or injected refrigerant. The kit is universally applicable and also allows observation of oil contamination, filtration of swarf. Applicable to all CFC, HFC, HFO and other refrigerants.

**MAIN APPLICATIONS**

When recharging refrigerant gas cylinders at an A/C service station;  
When recovering gas from the air conditioning system using a station or recuperator.

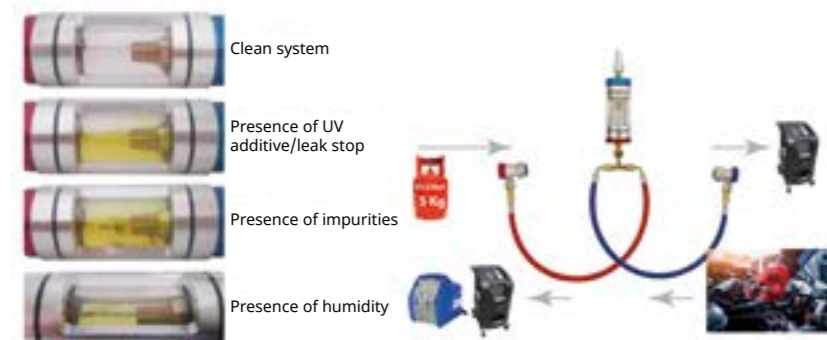

Example 1



Example 2

Example 3

# Filter kit for protecting the station during refrigerant recovery from a clogged AC system

## 007950027670

A filter kit designed for use with air conditioning units. It ensures that the unit's components remain clean and protected during refrigerant recovery from a system with a compressor fault. The kit includes a filter (part number 007950027675), which effectively aids in the preliminary purification of the refrigerant before it enters the machine, resulting in reliable operation of the unit.

**Items included:**



007950027675 - Filter for the set



Connectors



Cable



Valve unscrewing device for replacing valves without draining the refrigerant, adapters r134a +1234yf  
007950025200



Blue Hose 250 cm  
Ø 1/4" x Ø 1/4" SAE  
007950013760  
Blue Hose 250 cm  
Ø 1/4" SAE x Ø 1/4" SAE  
007950024730  
A/C Unit Hose - 250 cm For Refrigerant 1234yf Blue  
1/4"SAE X1234yf  
007950024960  
Blue Hose 4000 mm For Refrigerant R1234yf  
1/4"SAE X1234yf  
007950024965



Red Hose 250 cm  
Ø 1/4" x Ø 1/4" SAE  
007950013770  
Red Hose 250 cm  
Ø 1/4" SAE x Ø 1/4" SAE  
007950024720  
A/C Unit Hose - 250 Cm For Refrigerant 1234yf  
Red 1/4"SAE X1234yf  
007950024950  
Red Hose 4000 mm For Refrigerant R1234yf  
1/4"SAE X1234yf  
007950024955



LP CO2 quick coupling  
007950027370



HP CO2 quick coupling  
007950027380



Quick Coupler LP 1/4" 16 mm  
007950013780



Quick Coupler HP 1/4" 16 mm  
007950013790



Quick Coupler 180° 1/4" LP  
007950024000



Quick Coupler 180° 1/4" HP  
007950024010



Quick Coupler Hp For 1234yf  
1/2" ACME M14 x1.5  
007950024930



Quick Coupler Lp For 1234yf,  
M14 x1.5  
007950024940



Quick Coupler HP M14 x1.5 with connector on 1/4" SAE Male  
007950025230



Quick Coupler LP M14 x1.5 with connector on 1/4" SAE Male  
007950025240



Quickcoupler Parker® low pressure LP M14x 1.5 mm  
007935020080



Szybkozłącze Parker - wysokie ciśnienie 1/4" SAE  
007935020100



Quickcoupler Parker® high pressure HP 1/4" SAE  
007935020110



Quickcoupler Parker® high pressure HP M14x 1.5 mm  
007935020090



Quickcoupler LP HFO 1234 yf Parker  
007935020120



Quickcoupler HP HFO 1234 yf Parker  
007935020130



Quick Coupler BMW  
007950024560



BMW, Ford quick coupling extended for R1234yf HP  
007936211119



BMW, Volvo, Ford R134a HP adapter extension, straight  
007935021100



Quick Coupler For Renault Hp-Lp  
007950025250



180 HP quick coupling for R1234yf  
007936211118



180 LP quick coupling for R1234yf  
007936211121



Extension for LP port to factor R1234yf  
007950027040



Extension for LP port to factor R1234yf  
007950027070



UV Lamp 12V/50W (Additionally Oil With UV + Uv Dye Cleaner)  
007935090120  
Allows for a quick leak localization in the system by the use of an electronic probe or a UV lamp.  
• 6 sensitivity degrees (15 detection degrees)  
• three-color electronic scale indicating the volume of leakage  
• detects leaks up to 3 gr/year  
• detects all CFC, HCFC, HFC agents  
• flexible probe 43cm long



UV Lamp 100 W  
007950024700

- UV lamp 100W
- Safety glasses



Special Uv Glasses  
007950025280



Manual Flushing Kit  
007950024750

SET FOR AIR CONDITIONING FLUSHING SYSTEMS MANUAL (SET TERMINAL + CYLINDER + TANK). Rinsing package is powered by compressed air. Cylinder filled with liquid enables pulsed manual lavage systems.



A/C flush spray 600ml  
007950025960



50W UV lamp with charger and glasses 007950025190  
the set includes:  
50W UV lamp with charger and glasses (internal battery and glasses)



Electronic Leak Detector With Uv Lamp  
007950013850  
Allows for a quick leak localization in the system by the use of an electronic probe or a UV lamp.  
• 6 sensitivity degrees (15 detection degrees)  
• three-color electronic scale indicating the volume of leakage  
• detects leaks up to 3 gr/year  
• detects all CFC, HCFC, HFC agents  
• flexible probe 43cm long  
• battery test  
• very bright UV diode lamp



Ac Flushing Fluid 1 l flammable  
007950024530



Ac Flushing Fluid 5 l flammable  
007950024540

Ac Flushing Fluid 20 l flammable  
007950024550

Ac Flushing Fluid 1 l non-flammable  
007950026620

Ac Flushing Fluid 5 l non-flammable  
007950026630

Ac Flushing Fluid 20 l non-flammable  
007950026640



Adapters Kit For Flushing Machine - Basic  
007950025000



Adaptors Kit For Manual Flushing  
007950024740



Professional set of terminals for flushing devices, dedicated for European and American cars  
007936210020



# Hydrogen kit 007950025880

**NITROGEN/HYDROGEN LEAKAGE TEST KIT (1KG HYDROGEN CYLINDER, REGULATOR, 40 BAR PRESSURE GAUGE, DETECTOR, SHUT-OFF VALVE)**



The refrigerant leak detector (H2) allows a hydrogen leak to be detected quickly. Its sensitivity is 5 ppm. A new forming gas mixture of 5% hydrogen (H2) + 95% nitrogen (N) is used as a refrigerant and in air conditioning systems. For this reason, a good leak detector can help with maintenance and leak detection, thereby increasing refrigerant performance.

- Microprocessor-based control with advanced digital signal processing.
- Multi-colour display.
- Selector switch for high-medium-low leak detection sensitivity.
- Low battery indicator.
- Solid-state gas sensor.
- Detecting a mixture of 5% hydrogen (H2) + 95% nitrogen (N).
- Case included.
- 15.5" (40 cm) flexible stainless steel probe.
- Reference leakage source attached.
- Resetting the ambient concentration.
- Brushless DC fan with long service life.
- Automatic zero and background compensation.



Nitrogen/hydrogen leakage test kit

included:  
2.2 kg hydrogen cylinder, regulator, 50 bar pressure gauge, detector, shut-off valve  
007936211590



Cylinder With Hydrogen 1 l  
007950025890



Cylinder With Hydrogen 2,2L  
007950025892



**Electronic Leak Detector Hydrogen**  
007950025820

Enables quick location of leakages in the system using an electronic probe with acoustic or visual leakage alert.  
Detected gases:  
Mixture of 5% hydrogen (H2) + 95% nitrogen (N). Sensitivity: below 5 ppm.

|                  | H       | M        | L        |
|------------------|---------|----------|----------|
| 95% N2,<br>5% H2 | 2g/year | 15g/year | 30g/year |

**FEATURES AND SPECIFICATION:**

- 3 sensitivity degrees (5 detection levels)
- electronic scale for leakage severity notification
- detects leakages up to 3 g/year
- detects the mixture of hydrogen and nitrogen
- flexible 43 cm probe, battery test
- acoustic alarm signalling leakage severity



**Hydrogen Electronic Leak Detector 1234yf**  
007950025830

**ELECTRONIC DETECTOR LEAK**

Allows you to easily locate the leak in the system with the help of electronic signaling probe audibly or visually leak.

**Specifications:**

Detectable gases R-134A, R-404A, R407C, R-410A, R-22, etc. 1234yf.

**Sensitivity:**

H M L R22,134a 3 g / year 15 g / year 30 g / year  
R-404A, 407C, 410A 4 g / year 20 g / year 40 g / year  
1234yf 3 g / year 15 g / year 30 g / year

Alarm mode: buzzer, diode bar, tri-color indicator  
Used Power: 4 AA alkaline batteries (6V DC)  
Cable length: 40 cm (15.5")  
Dimension / Weight: 173 x 66 x 56 mm (approximately 400 g)  
Accessories: Alkaline batteries - 4 pieces.  
Manual, bottle leakage control, carrying case for transporting



**Electronic Professional CO2 Leak Detector (R744)**  
007950027360

The fully automatic Optima detector is very energy-efficient, handy but also highly sensitive, and locates even the most difficult leaks. It is ideal for repairing refrigeration systems based on carbon dioxide or any general purpose, which is designed to detect leaks, where compressed carbon dioxide can be used as the test gas.  
Also in the latest models of Mercedes or Audi vehicles, using R744.

**Specification:**

- Microprocessor control with advanced digital signal processing.
- Colour display.
- High-medium-low leakage detection sensitivity switch.
- Optical gas sensor.
- Detection gas: R744 (CO2)
- Case included.

**Technical specifications:**

- Warm-up time: 45 sec.
- Operating temperature: 0 °C to 40 °C (32 °F to 104 °F)
- Dimensions: 222 mm x 66 mm x 51 mm
- Weight: 418 g (with battery)
- Energy consumption: Lithium-ion battery 3.7 V DC.
- AC power supply: 5 V 1 A



**Electronic leakage detector, refrigerants: HFC, R134A, R1234yf, Hydrogen**  
007950027000

- Microprocessor control with advanced digital signal processing.
- Colour display.
- High-medium-low leakage detection sensitivity switch. Low battery indicator.
- Semi-conductor gas sensor.
- Detects the mixture of 5% hydrogen (H2) + 95% nitrogen (N).
- Case included.
- 15.5" (40 cm) flexible stainless probe.
- Included referential leakage source.
- Resetting environment concentration.
- Heavy-duty, brushless DC fan.
- Automatic zero and background compensation

**Specifications**

Detected gases: R-134A, R-404A, R407C, R-410A, R-22, 1234yf, etc.

**Sensitivity:**

Detected gases: Mixture of 5% hydrogen (H2) + 95% nitrogen (N).  
Sensitivity: below 5 ppm.

|                    | H       | M        | L        |
|--------------------|---------|----------|----------|
| R22,134a           | 3g/year | 15g/year | 30g/year |
| R-404A, 407C, 410A | 4g/year | 20g/year | 40g/year |
| 1234yf             | 3g/year | 15g/year | 30g/year |

|               | H       | M        | L        |
|---------------|---------|----------|----------|
| 95% N2, 5% H2 | 2g/year | 15g/year | 30g/year |

Alarm mode: buzzer, LED strip, three-colour indicator  
Power supply: 4 alkaline AA batteries (6V DC)  
Cable length: 40 cm (15.5")  
Dimensions/weight: 173 x 66 x 56 mm (approximately 400 g)  
Accessories: Alkaline batteries - 4 pcs.  
Instruction manual, leakage testing bottle, transport case  
Battery autonomy: approx. 7 hours of normal use  
Automatic switch-off: 10 minutes  
Automatic switch-off deactivation: press the "Hi" button and switch off the device  
Heating up time: approx 45 seconds  
Operation temperature and humidity: 0 - 40°C, <80% RH  
Storage temperature and humidity: -10 - 60°C, <70% RH  
Altitude above sea level: <2000M (6500')

**Kit for nitrogen testing up to 35 bar complete**  
007936210760

- Included:**
- 35 bar reducer
  - 2.5 m cable
  - HP R134a quick coupler
  - 40 bar test gauge
  - connection cable 1m yellow
  - suitcase



**Sensor for electronic leak detector**  
007950014310

Sensor for electronic leak detector, multi-purpose (007950027000)  
007936211110

**Sensor for electronic leak detector, hydrogen**  
(007950025820)  
007950027010

Sensor for electronic leak detector, R1234yf  
(007950025830)  
007936210740

Protective cap for leak detectors without thread (old type) (Pasuje do 007950025830, 007950027000, 007950025820)  
007936211340



**Diode UV**  
430104017590



**Manometers Set 1/4" 63 mm without hoses**  
430104017091



**Pressure gauges for refrigerant 1234yf**  
007950024715



Gauge for checking for leaks in automotive air conditioning systems filled factor 1234yf. The kit consists of two pressure gauges mounted on a common manifold equipped with a connector pipes.  
( WITHOUT CABLE )

**Pressure gauge set (scale R1234a, R1234yf, R32, R4110A), 2.5m cables, quick couplers R134, key in case**  
007950024710

- Set contains:**
- case, manometers,
  - 3 hoses (2.5 m),
  - 2 quick couplings



**Pressure gauge set for factor 1234yf (scale R1234a, R1234yf, R32, R4110A), hose 2.5 m, quick couplings R1234yf, key in case**  
007950024725

Set for a comprehensive checking leaks in automotive air conditioning systems operating on 1234yf factor. Zawiera set of gauges, hoses and quick-wrapped in aesthetic and durable carrying case.



**Mobile Set For Nitrogen Tests (1 kg Nitrogen Bottle, Reducer, Pressure Gauge 40 Bar)**  
007950025860

Leak test kit for automotive air-conditioning system with nitrogen.

**The kit includes:**

- Case of polypropylene
- Pressure regulator for cylinders with a capacity of 5 liters
- Pressure gauge with hose and a three-way valve
- The yellow wire 1500mm
- Bottle Hydrogen (a mixture of nitrogen and hydrogen)- 1 liter
- Reduction for cylinders with a capacity of 1 liter
- Leak Detector hydrogen



**Leak Finder 400 ml**  
007950024690



**Manometer 40 Bar with hose 30 cm and valve**  
007950025870



**UV Dye Remover 400 ml**  
007950025270



**Nitrogen 1 l**  
007950024980



**Pressure Reducer For Nitrogen 1 l**  
007950025310



**Pressure Reducer For Nitrogen Professional (Max 34 Bar)**  
007950024990



**Leak test kit for CO2**  
007950027520



**CO2 refrigerant cylinder for MB**  
007950027570  
Refrigerant weight: 420 grams/  
empty cylinder: 935 grams



**CO2 refrigerant cylinder for VW AUDI**  
007950027565  
Refrigerant weight: 340 grams/  
empty cylinder: 926 grams



## YOUR CHOICE PAYS!

- AC FLUSH PRO (WITHOUT ADAPTERS)

- This is what you are looking for! 007935110700



This is a new version of the device used for comprehensive service of air conditioning systems - replacements of system fluids and removal of contaminants generated during the operation. The AC FLUSH PRO device works on a 12 V car battery power supply to enable its use independently of the power grid, e.g. outdoors. Compact construction enables carrying AC FLUSH PRO in smaller vehicles and makes it easier to fit in tighter spaces. The device is capable of high pressure operation. This means you can feel safe even in unpredicted situations. As one of the few devices available, it provides a printed flushing process report.

### TECHNICAL SPECIFICATIONS:

Cables, hydraulic components, accessories: Group of three-way, round cross-section, steel conduits with Viton seals. Internal electric wire - IDEALCARBUR 3/4 with external insulation protecting the cables in the charging section.  
Pump: Maximum flow rate = 4.5 l/min;  
Maximum pressure = 5 bar  
Dimensions:  
Width = 610 mm,  
Height = 1030 mm,  
Depth = 560 mm  
Weight: ~50 kg  
Operating temperature: +7 °C to +40 °C



007935110020  
AC filter for AC FLUSH PRO



## Pneumatic device for flushing air conditioning systems with pulsation (without adapters)

### SUPER FLUSH 007936210770

Super Flush is an innovative solution dedicated to professionals, servicing and servicing air conditioning systems in all types of vehicles. The device allows to clean the interior of the system and remove deposits, oil deposits or metal filings that appear when the air conditioning compressor is damaged. Pulse rinsing and the ability to change the direction of rinsing are the most effective cleaning methods that Super Flush allows. This effective device also has a smooth regulation of pulsation pressure and 2 filters, one metal-coarse cleaning, the other microfiber - allowing the removal of the smallest impurities. The 4 L tank allows you to flush almost any system with a capacity of 3-4 kg. The device is not standard equipped with adapters, which need to be purchased separately.

### INCLUDED:

- Super Flush device
- 2 wires 2m with 1/4 „thread
- a spare microfiber filter
- a key to replace the filter
- funnel
- instrukcja obsługi

### TECHNICAL PARAMETERS:

Tank capacity: 4l  
Pressure: 5 - 7 kg / cm2  
Dimensions: 520 x 520 x 900  
Weight: 25 kg

### CHARACTERISTIC:

- the device is completely safe when working with solvents
  - the device does not have sparking components
  - the drive comes from a pneumatic pulse pump
  - device equipped with 2 filters - accuracy 1um and 5 um
  - dedicated for use with flammable air conditioning fluids
- Filter for Microfibre Super Flush device - 007936211000



007936211000  
Device filter  
Super Flush with  
microfiber

Professional set of adapters for flushing devices  
007936210730



Orings And Spring Locks Set (Ford and GM) (60 pieces)  
007935090930



Set For Fixing Hoses And Quick Couplers (90 pieces)  
007935090931



Set Purple Orings for AC Systems (265 pcs):  
(5 x 1,5 - 20 pcs.; 6,07 x 1,78 - 20 pcs.; 7,65 x 1,78 - 15 pcs.; 10,82 x 1,78 - 15 pcs.; 14 x 1,78 - 15 pcs.; 6,8 x 1,9 - 15 pcs.; 7 x 2 - 15 pcs.; 12,42 x 1,78 - 15 pcs.; 6,5 x 1,5 - 15 pcs.; 7,5 x 1,5 - 15 pcs.; 10,8 x 2,4 - 10 pcs.; 13,8 x 2,4 - 10 pcs.; 15,2 x 2,4 - 10 pcs.; 17,2 x 2,4 - 10 pcs.; 19,2 x 2,4 - 10 pcs.; 14,8 x 3,1 - 10 pcs.; 19 x 3,5 - 10 pcs.; 17,8 x 3,1 - 10 pcs.)  
007936210720

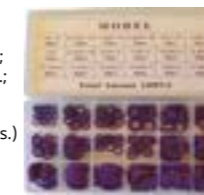

Fiat Group Orings Kit  
007935090690



Universal Orings Set (172 pieces)  
007935090750



Standard Orings Set (120 pieces)  
007950024080



Special Orings Set (88 pieces)  
007950024090



Set Of Orings Full (361 pieces)  
007950025510



Set of 28 orings - 400 pieces  
007950025520



Sealing Washers Set  
007950025090



Sealants 4 pieces diameter Ø 17,7 mm  
007950025530  
Sealants 4 pieces diameter Ø 14,7 mm  
007950025540  
Sealants 4 pieces diameter Ø 11,7 mm  
007950025550



ORing N° 6 (10 pieces) 007950024150

ORing N° 10 (10 pieces) 007950024160

ORing N° 8 (10 pieces) 007950024170

Oring Evaporator 007950024180

Oring 11.13 X 9.25 Press. M (10 pieces) 007950024200

Oring 6.7 X 5.1 (10 pieces) 007950024205

Oring 7.5 X 10.3 G6 Denso (10 pieces) 007950024210

Oring 24.4 X 20 Comp. Denso (10 pieces) 007950024220

Oring 12.7 X 10.3 G8 Denso (10 pieces) 007950024230

Sealing Oring, Inner Diameter. 17,7 mm (3 pieces) 007950024260

Sealing Oring, Inner Diameter. 17,7 mm (3 pieces) 007950024260

Sealing Oring, Inner Diameter. 14,7 mm (3 pieces) 007950024270

Sealing Oring, Inner Diameter. 11,7 mm (3 pieces) 007950024280

Sealing Oring, Inner Diameter. 8,7 mm (3 pieces) 007950024290

Dubble Oring, Outer Diameter 15.4 mm (5 pieces) 007950024300

Dubble Oring, Outer Diameter. 10 mm (5 pieces) 007950024310

Dubble Oring, Outer Diameter. 18 mm (5 pieces) 007950024320

Oring 24.4 X 20 Denso (10 pieces) 007950024330

Oring 23.7 X 20,22 Harrison (10 pieces) 007950024340

Oring 9 mm (10 pieces) 007950024360

Oring Peugeot 6460P2 (5 pieces) 007950024370

Oring Peugeot 6460P1 (5 pieces) 007950024380

Oring Renault 1-7701207274 (5 pieces) 007950024390

Oring Renault 2-7701207274 (5 pieces) 007950024400

Oring Renault 3-7701207274 (5 pieces) 007950024410

Oring 8 mm (10 pieces) 007950024450



Compressor sealing ring  
8mm/11,3mm (10 pcs.)  
007950026135

Compressor sealing ring 15mm/23,6mm  
(10 pcs.)  
007950026140

Compressor sealing ring 11mm/19,5mm  
(10 pcs.)  
007950026145

Compressor sealing ring 17mm/25,5mm  
(10 pcs.)  
007950026150

Compressor sealing ring 5/8" (15/28mm)  
(10 pcs.)  
007950026155

Compressor sealing ring 3/4" (17,7/31,6mm)  
(10 pcs.)  
007950026160



Set Of Caps And Service Ports  
007950025260



Protective Cap R134A Lp (2 pieces)  
M8\*1mm  
007950024240



| TABELLA TAPPI |                     |            |
|---------------|---------------------|------------|
| CODICE        | DESCRIZIONE         | CONFEZIONE |
| 007950024240  | Capo unico R134A LP | 1 PECCO    |
| 007950024241  | Capo unico R134A HP | 1 PECCO    |

Protective Cap R134A Hp (2 pieces)  
(2 sztuki) M8\*1mm  
007950024250



Protective Cap R134A Lp (2 pieces)  
- Japanese Cars M9\*1mm  
007950025290



Protective Cap R134A Hp (2 pieces)  
- Japanese Cars M10\*1.25 mm  
007950025300



HIGH PRESSURE CAP M10x1 (1 pieces)  
007950026245



LOW PRESSURE CAP M8x1 (1 pieces)  
007950026250



HIGH PRESSURE CAP M10x1,25 (1 pieces)  
007950026255



CAP LOW PRESSURE M9x1 (1 pieces)  
007950026260



CAP HIGH PRESSURE M10x1 (1 pieces)  
007950026265



LOW PRESSURE CAP M8x1 (1 pieces)  
007950026270



Adaptor Hp Ford M 10 X 1,25  
007950024800



Service Port 15 X 1,0  
007950024580

Service Port 13 X 1,1  
007950024590



Service Port Hp 12 X 1,5  
007950024600



Adapter M1/4 Sae X M1234yf  
007950025780



Adapter M3/8 Sae X M1234yf  
007950025790



ADAPTER Female 1/2" x Male 1/4"  
(1 pieces)  
007950026305



LP adapter  
to factor R1234yf x 1/4 „SAE  
007950027020

HP adapter  
to factor R1234yf x 1/4 „SAE  
007950027050



Adaptor for bottle  
R134 W21,8 x1/14 X 13 mm (big valve)  
007950024100



Adapter for bottle R134A  
W21,8 x1/14" X 13 mm (big valve)+ Adaptor  
for HP quickcoupler 1/4" SAE (7/16")  
007950024810



High Pressure Adaptor 1/4" X 13 mm  
007950024840



Hoses Connector 1/4 X 1/4" Sae  
007950024040



ADAPTER Female 3/8" x Male 1/4" (1 pieces)  
007950026275



ADAPTER Female 1/4" x Male 3/8" (1 pieces)  
007950026280



ADAPTER Male 1/4" x Male M14x1,5 (1 pieces)  
007950026285



ADAPTER Male 1/4" x Male 1/8 (1 pieces)  
007950026290



ADAPTER Female 1/4" x Female 1/4" (1 pieces)  
007950026295



Adapter on the bottle 3/8" (1 pieces)  
007950026300



Set of nozzles throttling  
(18 pieces)  
007950024570



| ORIFICE TUBE                   |  |
|--------------------------------|--|
| ORIFICE TUBE BLUE (FORD)       |  |
| ORIFICE TUBE GRAY (VALEO)      |  |
| ORIFICE TUBE YELLOW (VOLVO)    |  |
| ORIFICE TUBE WHITE (FAT)       |  |
| ORIFICE TUBE BROWN (FORD)      |  |
| ORIFICE TUBE BLACK (PELLI)     |  |
| ORIFICE TUBE PURPLE (CHRYSLER) |  |
| ORIFICE TUBE ORANGE (FORD)     |  |
| ORIFICE TUBE RED (FORD)        |  |
| ORIFICE TUBE GREEN (FORD)      |  |

Adapter Dupont To The Bottle  
For New Refrigerant  
007950025800



Adapter Honeywell To The Bottle  
For New Refrigerant  
007950025810



Dupont cylinder HP adapter  
07950026650



Honeywell cylinder HP adapter  
007950026660



Universal LP adapter for cylinders with 1234yf  
007950026670



Universal HP adapter for cylinders with 1234yf  
007950026680



BLUE ORIFICE TUBE (ford)  
007950026185



YELLOW ORIFICE TUBE (Volvo)  
007950026195



PURPLE ORIFICE TUBE (Chrysler)  
007950026215



RED ORIFICE TUBE (Ford)  
007950026225



GREEN ORIFICE TUBE (Ford)  
007950026230



Service Valves Kit (33 pieces)  
007950024070



Valve core Standard 21,8 x 8 mm (5 pieces)  
007950024470



Valve core Standard 22,1 x 9,8 mm (5 pieces)  
007950024480



AC Valve Kit with a Key (10 valves - 57pcs)  
007936210050



Valve with green Oring (3pcs),  
Renault Service Valve (5pcs),  
KIA/Hyundai Service Valve (5pcs),  
VW MW Valve with green Oring (3pcs),  
GM 10mm-Service Valve (3pcs),  
Volvo Peugeot Service Valve (5pcs),  
JRA Service Valve (5pcs),  
GM Service Valve (5pcs),  
Standard Service Valve (20pcs);  
Key to unscrewing valves



Valve core R12/R134 19 x 5,1 mm (10 pieces)  
007950024420



Valve core JRA 21,55 x 7,8 mm (5 pieces)  
007950024430



Valve core High Flow 20 x 7 mm (5 pieces)  
007950024440



Valve core Vw Gm 18,7 x 6 mm (5 pieces)  
007950024460



Valve core Large (Violet) 27,155 x 7,8 mm  
(1 pieces)  
007950024830



Service valve 21.8 MM X 8MM  
- HFO1234YF  
007950026690



Service valve 22.1 MM X 9.8MM - HFO 1234YF  
007950026700



Valve core Renault 18,35 x 5,1 mm (1 pieces)  
007950025400



Valve core Do Kia Hyundai 18,5 x 6,5 mm  
(1 pieces)  
007950025410



Hydraulic Press For Crimping  
007950016040

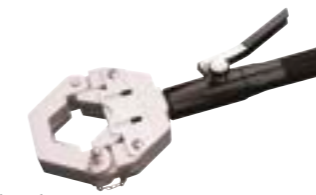

It is a universal, lightweight and handy device for crimping hoses in the air conditioning systems. By the use of Hydra Krimp hydraulic hand pump this operation is performed easily, quickly and precisely. This tool is ideal for use both in a workshop, as well as in the field.

**THE KIT INCLUDES:**

- HYDRAULIC HAND PUMP
- CABLE-CLAMPING JAWS
- HOSE CLAMPS (MATRIX) OF THE SIZES 6(5/16"), 8 (13/32"), 10 (1/2") I 12 (5/8") MM 6(5/16")SRB, 8 (13/32")SRB, 10 (1/2")SRB AND 12 (5/8")SRB MM
- REDUCTION CLAMPS WITH THE ABOVE MENTIONED DIAMETERS
- CARRYING CASE FOR ALL THE ELEMENTS

Manual Press For Crimping  
007950013860



It is a universal, lightweight and handy device for crimping hoses in air conditioning systems. Manual crimping of hose ends allows for a proper selection of crimping force. A solid foundation made of hardened steel allows for a convenient permanent mounting of the entire handle. It enables using of an ordinary manual or hydraulic wrench.

**THE KIT INCLUDES:**

- hose clamps (matrix) of the sizes 6(5/16"), 8 (13/32"), 10 (1/2") i 12 (5/8") mm
- cable-clamping jaws
- reduction clamps with the above diameter
- carrying case for all the elements

Hose Shears  
007950013870



Big Ratio Hose Shears  
007950025210



Hose Standard Barrier A/C 06 5/16"  
007935020960



Hose Standard Barrier A/C 08 13/32"  
007935020970



Hose Standard Barrier A/C 10 1/2"  
007935020980



Hose Standard Barrier A/C 12 5/8"  
007935021000



Hose Reduced Barrier A/C 06 5/16"  
007935021000



Hose Reduced Barrier A/C 08 13/32"  
007935021010



Hose Reduced Barrier A/C 10 1/2"  
007935021020



Hose Reduced Barrier A/C 12 5/8"  
007935021030



Hose Reduced Barrier A/C 14 3/4"  
007935021040



R134A - With 12 Kg Container  
007950014290  
R134A - With 12 Refrigerant  
(complete with 007950014290)  
007950014280



R1234yf refrigerant, 5 kg (007950014325), kit  
with 007950014561  
007950014325  
Reusable refillable cylinder, 12 kg  
(007950014561)  
007950014561



# OILS

## 100% SYNTHETIC POLYALCHILENGLYCOL (PAG) BASED LUBRICANTS FOR REFRIGERATING COMPRESSORS

### DESCRIPTION

The polyalchilenglycol (PAG) lubricants series are fully synthetic lubricants with high oxidation resistance features, specifically developed for the lubrication of rotary refrigerators compressors, that need a very low freezing point and very long drain intervals.

### PROPERTIES

- ▶ Products with superior features compared to traditional mineral based lubricants.
- ▶ Maximum duration of exercise, in order to extend the oil change intervals.
- ▶ Possible use with the widest temperature range (-30 °C to +50 °C).
- ▶ No carbon deposits in the hot spots of the compressor, thanks to the synthetic nature.
- ▶ Excellent protection against rust, corrosion and wear of the components.
- ▶ Avoids the formation of foam, to avoid the phenomenon of cavitation.



### APPLICATIONS

These lubricants are specifically suitable where the compressor manufacturer suggest a fully synthetic lubricant with polyalkylene glycol base oils (PAG). These products are particularly also suggested in cases of extreme temperature changes, and when it is necessary to maximize the life-service interval and consequentially minimize downtime and labor costs.

### WARNINGS

The polyalkyleneglycol base oils (PAG) series makes these product NON-compatible with conventional mineral- and synthetic-hydrocarbon based lubricants without polyalkylenglycols PAG. Before the lubricant drain, it is necessary to thoroughly clean the circuit. In case of change in the nature of the lubricant, if possible wash with solvent the entire system, ensuring that there are no residues of the old lubricant or washing fluid before the new filling. Keep the product in a dry place in tightly closed containers.

### PAG (46 AND 100) FOR HFO R-1234YF

PAG oils are mainly oils with singly closed chemical bonds. The PAG 46 and 100 version for HFO R-1234yf is based on special, stabilized polyalkylene glycols produced with the addition of the highest quality copolymers ensuring double-end-capped chemical bonds to meet the increased needs of refrigeration compressors. This means that the main chemical chain of the preparation is closed on both sides, whereas in the case of an oil with singly closed chemical bonds, the main chemical chain is closed on only one side. As a result, PAG oils with singly closed chemical bonds are still chemically active and react with moisture, possibly causing acid formation. Due to their nature, these oils are intended for use as "universal" for use with refrigerants such as R-134a and R-1234yf.

# LUBRICANTS

## LUBRICANTS (POE) FOR AUTOMOTIVE A/C SYSTEMS

### DESCRIPTION

These oil series are fully synthetic lubricating fluids, based on synthetic and biodegradable polyesters oils ( POE ) with a particular anti-wear additive package designed specifically for use in automotive air conditioning systems loaded with alternative refrigerants not detrimental to the ozone layer.

### TECHNICAL FEATURES

- ▶ Dielectric strength - IEC 60156 @ 24°C >75kV
- ▶ Complying with specification IEC 61099
- ▶ Higher lubricity values compared to traditional mineral-based lubricants.
- ▶ Excellent anti-wear performance for steel and aluminum surfaces, allowing to extend the life and efficiency of the system lubricated.
- ▶ Chemically and thermally stable products, compatible with residues of mineral oils or alkylbenzene which may remain in a system after the replacement by CFC or HFC.
- ▶ Miscibility with both mineral and synthetic oils (polyalphaolefin PAO or polyester - POE). In case of mixture with a different nature or viscosity lubricant, the characteristics and performance of the product may change.
- ▶ Rust and corrosion protection of metals, particularly copper alloys.
- ▶ Compatibility with coatings, elastomers and paints.
- ▶ Formulation with biodegradable, non- dangerous bases for human health, for the protection of the operators and the environment in case of accidental spillage.
- ▶ The products are NOT compatible with polyalkylene glycol (PAG) based oils.
- ▶ Not miscible with other types of oil (like POE)



### APPLICATIONS

These POE lubricants are specifically used in air conditioning systems of motor vehicles.

- ISO 80: specific for use in electric compressors or when a dielectric compressor lubricant is required (complies with specification IEC 61099)

### WARNINGS

The products are hygroscopic, and absorb the humidity and mist/ condensation in the air: it is recommended to carefully seal the packaging after use and store them in a dry place at temperatures between -20 °C and + 40 ° C. In the case of storage at below -20°C, it is recommended to heat the product above 20°C before use, to eliminate as much as possible any moisture.

### AVERAGE PHYSICAL AND CHEMICAL FEATURES (DATA ARE NOT SPECIFICATIONS)

| ISO Viscosity Grade ISO 3448                                   |                        | 80  |
|--|------------------------|---|
| Physical State at 20°C   |                        | Liquid, clear, pale yellow color          |
| Pour point   | °C                     | < -35                                     |
| Flash Point COC ASTM D 92                                      | °C                     | 250                                       |
| Density at 20°C  | Kg/mc                  | ~ 960                                     |
| Water solubility   |                        | Hygroscopic                               |
| Acid Value (degree of saturation)                              | Mg KOH/g               | < 0,1                                     |
| Biodegradability test  | OECD 301B              | > 60% (pass the test if > 60% in 28 days) |
| Water content  | ppm                    | < 50                                      |
| Dielectric strength IEC 60156 @ 24°C                           | kV                     | > 75 (89.5)                               |
| Complying with specification IEC 61099                         |                        | Complies                                  |
| Kinematic viscosity at 40°C                                    | cSt                    | 75-85                                     |
| Kinematic viscosity at 100°CW                                  | cSt                    | 9.3-9.9                                   |
| <b>ASHRAE (97 Std) Thermal Stability Test @ 175°C, 336 hrs</b> |                        |   |
| Appearance / Settling  |                        | Clear / Settling Free (None)              |
| Water content after test                                       | ppm                    | < 10                                      |
| Acidity after test (TAN)                                       | Mg KOH/g               | 0,75                                      |
| Viscosity change after test                                    | 20°C 40°C              | < 3%                                      |
| Metal content before and water test                            | Copper Steel Aluminium | No metal mobilization was observed        |

|   | Type of oil         | Type of gas   | Viscosity    | Sizes        | MM code      | SOME OEM NUMBER RELATED TO MM PRODUCTS  |
|---|---------------------|---------------|--------------|--------------|--------------|---|
| <b>COMPRESSORS MECHANICAL AND SELECTED EV/HEV</b> | <b>PAG</b>          | R134a         | 46           | 250ml        | 007935090710 | Dens Oil 8 ;ND8;PAG SP10;ZXL 100 PG;G 052 300 A2;G 052 154 A2;SPA2;G 052 535 M2;83 222 339 920;81 229 407 724 ;PAG RL244; VC-46;PS-D1;VC100YF;FD46XG; WSS-M2C300-A2;ATMOS GU 10; WSH-M1C231-B;MB 362.1;A 000 989 06 06 ;KLHOO-PAGS0;Polylub GLY 801;1161407-0 |
|   |                     |               |              | 1L           | 007935090660 |   |
|   |                     |               |              | 5xL          | 007950024500 |   |
|   |                     |               | 46 + UV      | 250ml        | 007950025570 |   |
|   |                     |               |              | 1L           | 007950025580 |   |
|   |                     |               | 68 +UV       | 1L           | 007950026410 |   |
|   |                     |               |              | 250ml        | 007950026400 |   |
|   |                     |               | 68           | 1L           | 007950026380 |   |
|   |                     |               |              | 250ml        | 007950026370 |   |
|   |                     |               | 68           | 5L           | 007950026390 |   |
|   |                     |               |              | 250ml        | 007935090720 |   |
|   |                     |               | 100          | 1L           | 007935090670 |   |
|   |                     | 5L            |              | 007950024510 |              |   |
|   |                     | 250ml         |              | 007950025590 |              |   |
|   |                     | 100 + UV      | 1L           | 007950025600 |              |   |
|   |                     |               | 250ml        | 007935090730 |              |   |
|   |                     | 150           | 1L           | 007935090680 |              |   |
|   |                     |               | 250ml        | 007950025610 |              |   |
|   |                     | R1234YF       | 46 "DC"      | 250ml        | 007950024920 |   |
|   |                     |               |              | 1L           | 007950027460 |   |
|   |                     |               | 46 + UV "DC" | 250ml        | 007950027465 |   |
|   |                     |               |              | 1L           | 007950027470 |   |
|   |                     |               | 100 "DC"     | 250ml        | 007950024925 |   |
|   |                     |               |              | 1L           | 007950027475 |   |
| 100 + UV "DC"                                     | 250ml               |               | 007950027480 |              |              |   |
|   | 1L                  |               | 007950027485 |              |              |   |
| R134a/R1234YF                                     | UNIVERSAL "DC"      | 250ml         | 007950027080 |              |              |   |
|   |                     | 1L            | 007950027090 |              |              |   |
|   | UNIVERSAL + UV "DC" | 250ml         | 007950027490 |              |              |   |
|   |                     | 1L            | 007950027495 |              |              |   |
| R134a   | 80                  | 250ml         | 007950024680 |              |              |   |
|   |                     | 250ml         | 007950024685 |              |              |   |
|   | R1234YF             | UNIVERSAL     | 250ml        | 007950027500 |              |   |
|   |                     |               | 250ml        | 007950027500 |              |   |
| <b>ELECTRIC COMPRESSORS (NOT SANDEN)</b>          | <b>POE</b>          | R134a/R1234YF | UNIVERSAL    | 250ml        | 007950027500 | ND-11;POE ZE-GLES RB100EV; Sanden SE-10Y, Honda 38899-RMX-A01, 38899-RJ-A01, RL85HM (38899-RLV-A01), DENSO ND-OIL 14, Honda 38899-50Z-G01 & 38899-50Z-G03   |
|   |                     |               |              | 250ml        | 007950027500 |   |
| <b>ELECTRIC/MECHANICAL COMPRESSORS</b>            | <b>PAG</b>          | R744(CO2)     | UNIVERSAL 68 | 250ml        | 007950027340 | ACC HV PAG oil ISO 68 for R744  |
|   |                     |               | UNIVERSAL 68 | 1L           | 007950027350 |   |

**"DC"- DOUBLE CAPPED**

## UV FLUORESCENT CONTRAST LIQUID FOR THE

### DESCRIPTION

UV additives are special UV fluorescent contrast liquids specially designed for the detection of refrigerant gas leaks in automotive air conditioning and refrigeration systems. Today the simplest and cheapest way to search for leaks, our UV additive offers high fluorescence thanks to which, equipped with a special UV lamp, we can easily search for refrigerant gas leaks in the AC/R system.

### TECHNICAL FEATURES

- ▶ Ease of use.
- ▶ Precise location of leaks.
- ▶ Non-hazardous and solvent-free product.
- ▶ It does not damage systems, machinery such as recovery and charging stations and does not damage the various components and materials of the system.
- ▶ Compatible and perfectly miscible with the refrigerant lubricants used in the system.
- ▶ High luminescence when exposed to UV lamp.d oils.

### REGULATIONS

Complies with SAE J2297 and SAE J2298 regulations

### USES AND LINES

This product has been designed for simple and effective use in both car air conditioning and refrigeration systems. This is why our offer includes two main lines of UV additives: one for the AUTOMOTIVE sector and one for the REFRIGERATION sector.

### AVAILABLE FORMATS

Our UV additives are available in twocap bottles with dispenser (250, 350 ml and 1 liter) and in 7,5 ml single-dose syringes.

### SAFETY INFORMATIONS

The product is not dangerous, but we always recommend the use of protective gloves and special UV glasses to search for leaks using a UV lamp.

### APPLICATION IN AUTOMOTIVE A/C SYSTEMS WITH CHARGING STATION

Introduce the contents of the bottle with 2 caps with dispenser into the appropriate container of the charging station and follow the instructions of the machine.

### APPLICAZIONE IMPIANTI A/C AUTOMOTIVE CON INIETTORE O SIRINGA MONODOSE

Introduce the contents of the bottle with 2 caps with dispenser and fill the appropriate injector (piston or syringe) with the desired quantity (7,5 ml per 1,5 kg of refrigerant gas).

### APPLICAZIONE IMPIANTI A/C AUTOMOTIVE CON INIETTORE O SIRINGA MONODOSE

#### INJECTOR ONLY:

Introduce the contents of the bottle with 2 caps with dispenser and fill the appropriate injector (piston or syringe) with the desired quantity (7,5 ml per 1,5 kg of refrigerant gas).

**INJECTOR AND SYRINGE:** Turn on the vehicle and the A/C system. Before connecting the injector or syringe to the system, completely fill the hose connected to it, thus letting out the air present inside. Therefore connect to the system via the charge valve on the low pressure side and introduce the UV additive into the system. Disconnect the injector or syringe from the system and clean any residual UV additive. Leave the A/C running for approx. 30 minutes. After putting on the appropriate protective goggles, inspect the parts where it is suspected that there may be a leak with a UV lamp. The spots at the leak will appear fluorescent. Once the leak has been repaired, clean the area stained by the UV additive with the appropriate detergent and repeat the entire operation.



## LEAK STOP DETECTION

### COMPATIBILITY INDICATION BETWEEN REFRIGERANT GAS AND LUBRICANT

| Refrigerant gas | mineral based | PAG based | POE based | PAO based | Refrigerant gas | mineral based | PAG based | POE based | PAO based |
|-----------------|---------------|-----------|-----------|-----------|-----------------|---------------|-----------|-----------|-----------|
| R23             |               |           | ✓         |           | R744            | CO2           |           | ✓         | ✓         |
| R32             |               |           | ✓         |           | R22             |               | ✓         |           | ✓         |
| R134a           |               | ✓         | ✓         |           | R123            |               | ✓         |           |           |
| R404A           |               |           | ✓         |           | R124            |               | ✓         |           |           |
| R407C           |               |           | ✓         |           | R401A           |               |           | ✓         |           |
| R410A           |               |           | ✓         |           | R401B           |               |           | ✓         |           |
| R413A           | ✓             |           | ✓         |           | R402A           | HCFC          |           | ✓         |           |
| R417A           | ✓             |           | ✓         |           | R402B           |               |           | ✓         |           |
| R419A           | ✓             |           |           |           | R403B           |               | ✓         | ✓         |           |
| R422A           | ✓             |           | ✓         |           | R408A           |               | ✓         | ✓         |           |
| R422D           | ✓             |           | ✓         |           | R409A           |               | ✓         | ✓         |           |
| R427A           |               |           | ✓         |           | R414B           |               | ✓         |           |           |
| R428A           | ✓             |           |           |           | R416A           |               | ✓         | ✓         |           |
| R437A           | ✓             |           |           |           | R11             |               | ✓         |           |           |
| R438A           | ✓             |           | ✓         |           | R12             |               | ✓         |           |           |
| R507            |               |           | ✓         |           | R13             |               | ✓         |           |           |
| R508B           |               |           | ✓         |           | R13B1           |               | ✓         |           |           |
| R1234yf         | HFO           | ✓         | ✓         |           | R113            | CFC           | ✓         |           |           |
| R170            | ✓             |           |           |           | R114            |               | ✓         |           |           |
| R600            | HC            | ✓         |           |           | R500            |               | ✓         |           |           |
| R1270           |               |           | ✓         |           | R502            |               | ✓         |           |           |
| R717            | NH3           | ✓         |           | ✓         | R503            |               | ✓         |           |           |

|  | Type of oil | Type of gas             | Bottle | MM code      | Syringe                      | MM code      |
|--|-------------|-------------------------|--------|--------------|------------------------------|--------------|
| COMPRESSORS MECHANICAL AND SELECTED EV/HEV | PAG         | R134a                   | 250ml  | 007935090640 | Pack of 12 x 7,5ml           | 007950025910 |
|  |             |                         | 1L     | 007950025320 | Pack of 12 x 7,5ml +adapter  | 007950026340 |
|  |             | R1234YF                 | 250ml  | 007950024915 | Pack of 12 x 7,5ml           | 007950026050 |
|  |             |                         | 350ml  | 007950024910 | Pack of 12 x 7,5ml +adapter  | 007950026360 |
|  |             | UNIVERSAL R134a/R1234YF | 250ml  | 007950027160 | Pack of 12 x 7,5ml           | 007950027510 |
|  |             |                         | 1L     | 007950027170 | Pack of 12 x 7,5ml +adapter  | 007950027515 |
| ELECTRIC COMPRESSORS (NOT SANDEN)          | POE         | UNIVERSAL R134a/R1234YF | 250ml  | 007950027505 | Pack of 12 x 7,5ml           | 007950026045 |
|  |             |                         |        |              | Pack of 12 x 7,5ml +adapters | 007950026350 |

### SYRINGE ADAPTERS FOR SEALS AND UV CONTRASTS

| SECTOR                 | ARTICLE                          |  |     |
|------------------------|----------------------------------|--|-----|
| AUTOMOTIVE R-134a      | Adapter for Syringe 007950025940 |  | NEW |
| AUTOMOTIVE R-1234yf    | Adapter for Syringe 007950027425 |  | NEW |
| REFRIGERATION F1/4 SAE | Adapter for Syringe 007950027250 |  | NEW |

### WHAT IS A LEAK STOP:

Special additive formulated for the repair of micro leaks in automotive AC systems.

- ▶ It is an economic way to repair micro leaks
- ▶ It can be applied as preventive action
- ▶ Does not contain polymers that hardens with moisture or oxygen
- ▶ It does not damage the system
- ▶ Compatible and perfectly miscible with lubricant and refrigerant

### HOW DOES IT WORK?

The sealant is injected or sucked by the vacuum into the refrigerant system from the low-pressure port, where it gets carried with the refrigerant around the system.

It doesn't clog up the leak but rather forms a thin oil layer over the pipes, fixing the leaks in different elements also orings where very often leakage appears

Leak Stop in can:

1. Make the vacuum of the A/C system.
2. Connect the leak stop to the charge valve on the low-pressure side of the A/C system and introduce the sealant.

PLEASE NOTE: if you use a flexible adapter, let the air inside the hose out, before to connect it to the system.

3. Disconnect from the A/C system.

Recharge the system following the manufacturer's instruction.

4. Let the system work for at least 30 minutes to allow the leak stop to work.

Leak Stop in Syringe:

ADVANTAGE: no need to empty and create vacuum in the system.



|  | Type of oil | Type of gas   | Can                                  | MM code      | Syringe                                  | MM code      |
|--|-------------|---|--------------------------------------|--------------|--|--------------|
| COMPRESSORS MECHANICAL AND SELECTED EV/HEV | PAG         | R134a   | 30ml                                 | 007950025330 | 30ml                                     | 007950025950 |
|  |             |   |                                      |              | 30ml + adapter                           | 007950027180 |
|  |             |   | + UV dye 40ml                        | 007950025140 | 40ml                                     | 007950026025 |
|  |             |   |                                      |              | 40ml + adapter                           | 007950027525 |
|  |             | R1234YF   | 30ml                                 | 007950027440 | 30ml                                     | 007950027530 |
|  |             |   |                                      |              | 30ml + adapter                           | 007950027535 |
|  |             |   | + UV dye 40ml                        | 007950027445 | 40ml                                     | 007950027540 |
|  |             |   |                                      |              | 40ml + adapter                           | 007950027545 |
|  |             | UNIVERSAL R134a/R1234YF   |                                      |              | 6ml                                      | 007950027100 |
|  |             |   |                                      |              | 6ml + adapter R134a                      | 007950027110 |
|  |             |   |                                      |              | 6ml + adapter R1234yf                    | 007950027120 |
|  |             |   |                                      |              | 6ml + adapters R134a/R1234yf with UV 8ml | 007950027550 |
|  |             |   | with UV 8ml + adapter R134a          | 007950027140 |  |              |
|  |             |   | with UV 8ml + adapter R1234yf        | 007950027150 |  |              |
|  |             |   | with UV 8ml + adapters R134a/R1234yf | 007950027555 |  |              |
| ELECTRIC COMPRESSORS (NOT SANDEN)          | POE         | UNIVERSAL R134a/R1234YF   | 30ml                                 |              | 007950027560                             |              |
|  |             |   | 30ml + adapters                      |              | 007950027450                             |              |
| HVAC Compressors                           | PAG         | R290/R600a  |                                      |              | 30ml                                     | 007950027430 |
| HVAC                                       | POE         | R11, R12, R13, R22, R123, R124, R134a, R141b, R32, R404A, R407C, R410A, R502, R503, R507A |                                      |              | 60 ml concentrate                        | 007950027435 |
|  |             |   |                                      |              | 60 ml regular use                        | 007950027210 |
|  |             |   |                                      |              | 12 ml single dose                        | 007950027300 |

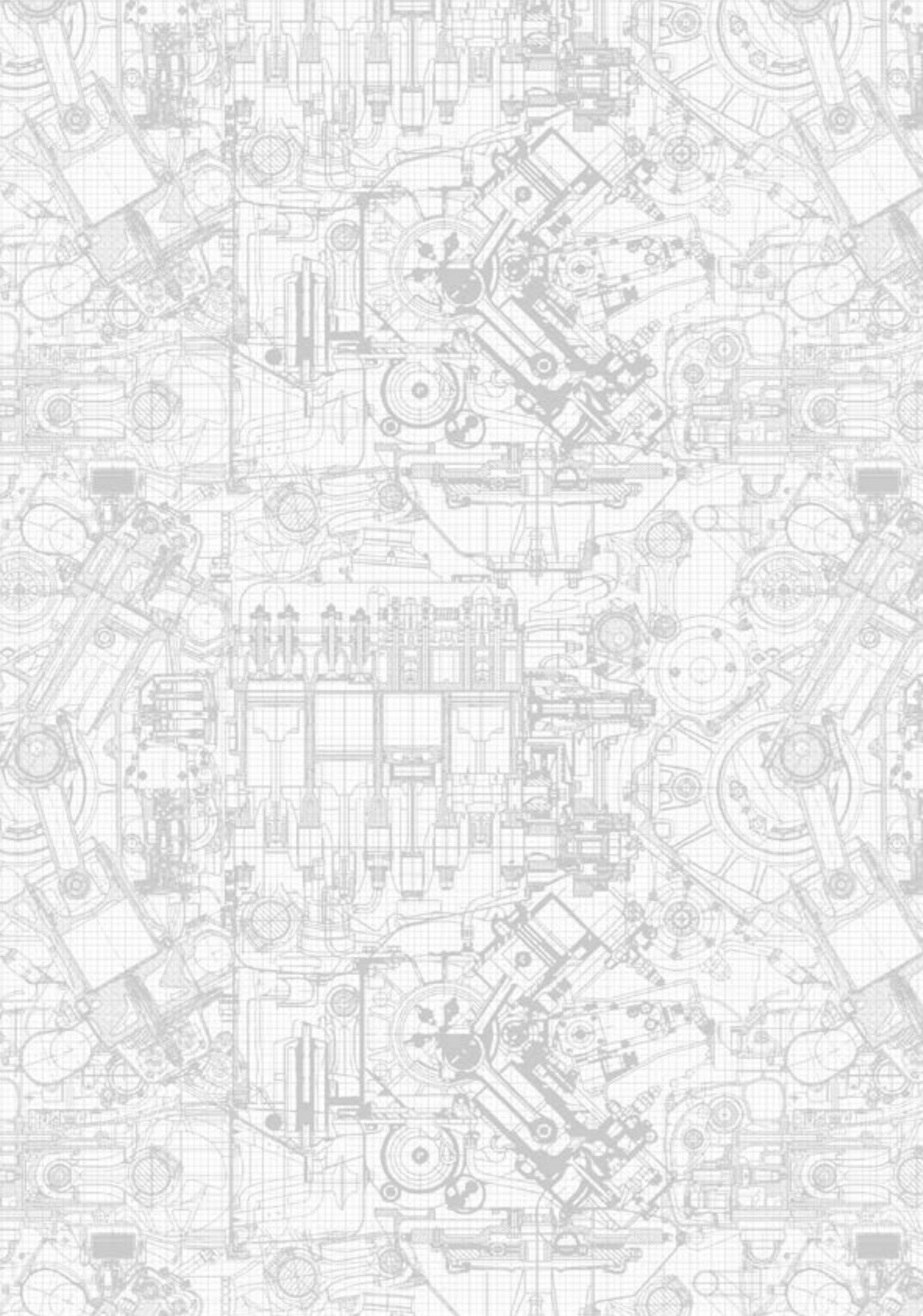

# DIAGNOSTICS



# DIAGNOSTIC KITS FOR YOUR WORKSHOP



## Data Box

- 007937000290 - Tablet Box
- 007937000010 - Data Box Interface
- 007937000040 - Data Box Diagnostic Licence

+ Data Box licence (annual subscription)



## Data Box SGW

- 007937000290 - Tablet Box
- 007937000010 - Data Box Interface
- 007937000040 - Data Box Diagnostic Licence
- 007937000310 - Annual subscription to the SGW package

+ Data Box licence (annual subscription)  
 + SGW\* (annual subscription)



## Data Plus

- 007937000000 - Visual Plus Tablet - diagnostic tester
  - 007937000005 - Data Plus VCI interface
  - 007937000045 - Licencja diagnostyczna Data Plus
- + Data Plus licence (annual subscription)



## Data Plus SGW

- 007937000000 - Visual Plus Tablet – diagnostic tester
- 007937000045 - Data Plus diagnostic licence
- 007937000310 - Annual subscription to the SGW package
- 007937000005 - Data Plus VCI interface

+ Data Plus licence (annual subscription)  
 + SGW\* (annual subscription)



## Marelli diagnostic series

|                    | Visual Plus & Data Plus | Data Plus | Tablet Box & Data Box |
|--------------------|-------------------------|-----------|-----------------------|
| <b>DIAGNOSTICS</b> |                         |           |                       |
| Multiple makes ➔   | ● (1)                   | x         | ● (3)                 |
| Remote ➔           | ●                       | ●         | x                     |
| Pass-Thru ➔        | ●                       | ● (2)     | x                     |

## SGW

FIAT, ALFA ROMEO, LANCIA, ABARTH, HYUNDAI, KIA, FORD, RENAULT, DACIA, JEEP, MASERATI, MERCEDES, VAG Group

This is not required for remote diagnosis. In Pass-Thru diagnostics, where required by the manufacturer.

FIAT, ALFA ROMEO, LANCIA, ABARTH, HYUNDAI, KIA, FORD, RENAULT, DACIA, JEEP, MASERATI, MERCEDES, VAG Group

- (1) It features advanced coding/programming functions (e.g. ECU replacement)
- (2) Requires a PC running Windows 10/11 for Pass-Thru diagnostics
- (3) Multi-brand diagnostics, compatible with Visual Plus or other Android tablets



| Additional accessories |  |
|------------------------|--|
| 007937000015           | EV battery diagnostic kit  |
| 007937000020           | A pledge of cables and a software licence for the Tesla brand                          |
| 007937000025           | 4-channel oscilloscope   |
| 007937000030           | Measurement module for an oscilloscope   |
| 007937000035           | Signal generator   |
| Software for testers   |  |
| 007937000050           | An additional 12 months of Data Plus updates (only when the device is first activated) |
| 007937000055           | An additional 24 months of Data Plus updates (only when the device is first activated) |
| 007937000060           | An additional 12 months of Data Box updates (only when the device is first activated)  |
| 007937000065           | An additional 24 months of Data Box updates (only when the device is first activated)  |
| 007937000070           | Data Plus annual subscription  |
| 007937000075           | Data Box annual subscription   |
| 007937000095           | Database licence (only when the device is first started)                               |
| 007937000100           | Annual database subscription   |

Marelli Aftermarket Poland has taken the utmost care in compiling this leaflet. However, it accepts no liability for any errors or omissions and reserves the right to make changes to the content without prior notice. We encourage users to submit comments, point out inaccuracies and make any other suggestions so that the next edition of the leaflet may be even better. It is prohibited to reproduce, even in part, the content of this leaflet without the prior written consent of Marelli Aftermarket Poland, which will protect its rights in accordance with the law.

## Professional wheel alignment MM Volante 3D Wheel alignment machine - 007935013835 MM Volante 3D

### VERSION WITH FIXED CAMERA POSITIONS

A wheel alignment machine designed for universal use, offering a choice of four camera height settings. This solution allows for precise adjustment of the working configuration depending on the installation conditions – whether the machine is installed within an inspection bay or when working with a car lift. Flexible camera positioning ensures optimal measurement conditions, enhancing user comfort and the accuracy of adjustments in various workshop environments.

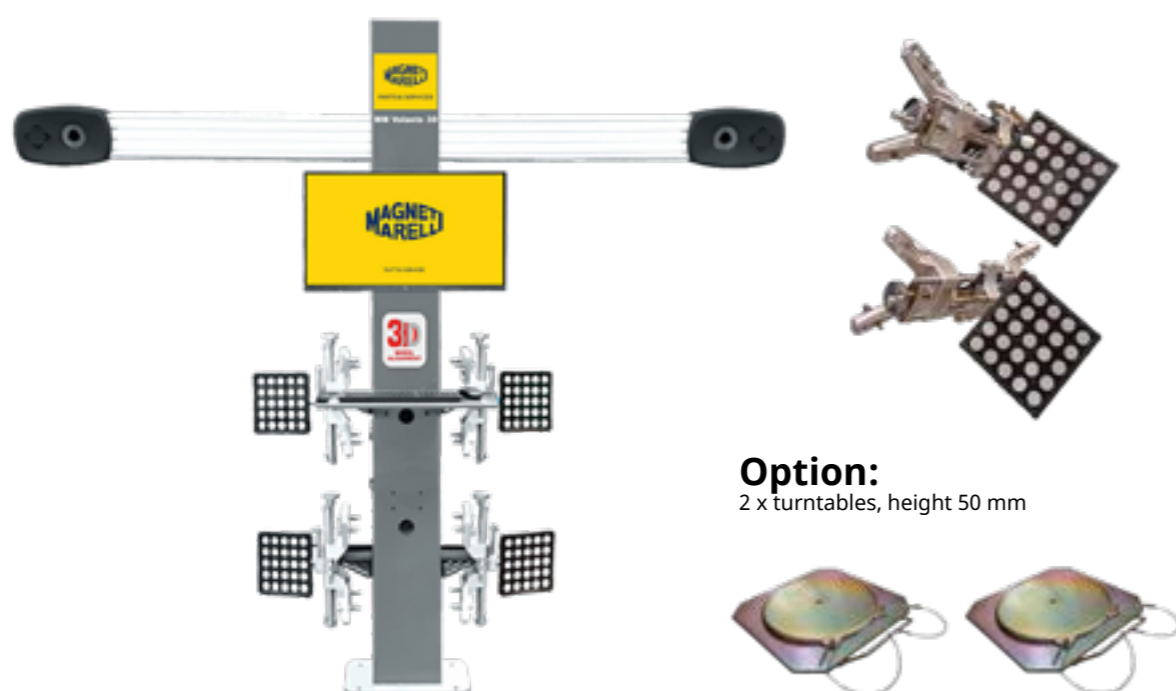

**Option:**  
2 x turntables, height 50 mm



## Wheel alignment machine MM Volante 3D AUTO - 007935013915 - VERSION FOR LIFT WITH ADJUSTABLE CAMERA POSITIONS

A wheel alignment machine featuring a lift that allows for height adjustment of the cameras, enabling easy and precise adaptation of the system to working conditions. The design allows for seamless operation with a diagnostic lift, ensuring convenient access to the vehicle and optimal measurement conditions.



The kit includes a mobile cabinet equipped with a PC, two monitors, and mounts for measuring heads, creating a complete, ergonomic workstation. The entire system has been designed to ensure efficient workspace organization, high user comfort, and smooth execution of diagnostic procedures in a workshop environment.

### Order fulfillment:

- ▶ Database – approximately 50,000 passenger car and light commercial vehicle models.
- ▶ Free updates
- ▶ PC + monitor Intuitive, easy-to-read application menu
- ▶ 4 wheel chocks (12"–24") with alignment targets
- ▶ Brake and steering wheel locks, wheel chocks for diagnostic testing in a workshop setting.

## Wheel alignment machine MM Volante 3D PRO - 007937000590 MOBILE VERSION

NEW



An advanced, state-of-the-art plug-and-play 3D wheel alignment system, designed for maximum convenience and efficiency in the workshop.

The system is equipped with mobile infrared cameras featuring magnetic mounts for the lift frame, ensuring quick installation and stability during measurements.

The device is compatible with both 4- post and scissor lifts, offering high flexibility of use. The 3-point wheel clamps ensure precise and secure mounting of the targets, resulting in accurate alignment



The system works with a tablet (Tablet Box; 007937000290) equipped with intuitive software and an extensive database, which simplifies operation and reduces measurement time. The kit includes a secure storage case for the cameras that also charges them simultaneously.

The entire system operates wirelessly, enhancing user comfort and maintaining order in the workplace. The database is updated via Wi-Fi, ensuring constant access to up-to-date information without the need to connect additional devices.



**checkstar ReTIS**

### Software for workshops

TRUCK VERSION ALSO AVAILABLE

**ReTIS**  
099992670300  
Retis On Line Workshop  
Software Yearly Licence

**ReTIS Truck**  
099992670405  
Retis Truck-Truck Software  
12 Months  
Licence On-Line



### Repairing Technical Information System

Currently, in order to fulfill the needs of a professional car workshop, technical documentation provided in a printed form is not sufficient. To meet the customers' expectations, Magneti Marelli have created the ReTIS programme - an effective instrument for fast technical consultation in all operating car parks. New content, further adapted to the current needs, and renewed graphics make the programme even more user friendly. Retis system is a large database that includes technical information concerning passenger cars and trucks, with petrol and diesel engines. The programme is available on a CD or in the form of an On-Line access. Programme license is issued in the form of an annual subscription, thanks to which free updates are available to the customers. 099992670400 (On-line)

#### RETIS IS A BANK OF TECHNICAL DATA THAT SUPPORTS A MECHANIC DURING DIAGNOSING AND REPAIRING OF DEFECTS.

The system includes information on:

- ▶ vehicle identification
- ▶ planned technical reviews
- ▶ information on the adjustments performed
- ▶ lubricants and operating fluids
- ▶ technical data concerning the engine and the adjustments
- ▶ technical drawings
- ▶ engine control (and localization of the components)
- ▶ ABS
- ▶ Air- Bag
- ▶ fuses and relays
- ▶ air-conditioning
- ▶ electrical connections schematics
- ▶ repair and maintenance times
- ▶ bodywork (disassembly and assembly of components)
- ▶ comfort systems (electrical schematics and functioning)
- ▶ EOBD error codes interpretation



- RETIS offers:**
- OVER 7,000 DRIVE UNITS
  - MILLIONS OF DETAILED OPERATING HOURS
  - MILLIONS OF ELECTRICAL DIAGRAMS
  - OVER 6,600 ENGINE CONTROL SYSTEMS
  - OVER 50,000 TECHNICAL DRAWINGS

#### Maintenance

- ▶ List of operations required during the control reviews

#### Engine - repair instructions

- ▶ Clear pictures with explanation and indication of the repaired areas, and with the values required for a proper control and adjustment.

#### Elektronics - engine control

- ▶ Components setting and adjustment, with a schematic of electrical connections and of the connections between the system components. Clicking on a description opens a corresponding page.

#### Adjustment data

- ▶ A wide range of information on the adjustments: from the engine to the tires.

#### Exterior/interior

- ▶ Data, drawings and repair guidelines for the systems situated in the cabin and in the body 6.600 engine control systems Thousands of electrical connections schematics Millions of specified repair times

## Service & Repair

009999269500

### The base provides a wide range of information about:

- ▶ Diagnostics
- ▶ Maintenance
- ▶ Repairs for workshops

### Also:

- ▶ More than 14000 models in the database
- ▶ Parameters directly from manufacturers
- ▶ Access to all databases of update data
- ▶ Cost calculator
- ▶ Assignment of elements
- ▶ Interactive connection diagrams
- ▶ Easy to move between works
- ▶ Quick fault code search

A range of materials and instructions together with drawings provides comprehensive support for vehicle mechanics of any type and avoids potential errors in providing services in the field of automotive technology.



Service drawings

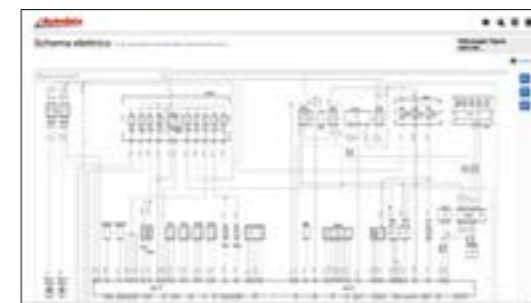

Electrical diagrams



### Technical information leader

Autodata, founded in 1975, is the world's leading provider of technical information on the aftermarket. Our mission is "to be the most innovative, accurate and respected supplier of technical information on the aftermarket". To achieve this, the basis of our philosophy is a continuous involvement in innovative solutions that allow for creation universal products that we design in response to our customers' needs. We are able to achieve this with our highly qualified 180 experienced staff in seven countries in the world. Most of them are directly involved in product development.

We create products that are used in workshops during repair and service of vehicles. Our database, including over 29,000 models from around the world, obtained direct license from more than 80 car manufacturers.

The information we provide is the result of a study by our specialists with experience in the automotive industry, perfectly understand the functioning of vehicles and the way in which technical information is applied in a modern car workshop.

This information is edited by us in such a way that it retains the same style and format, so you do not need extra interpretation when the work is done on models of different manufacturers. Our internal team of computer graphics creates detailed supportive illustrations that complement the technical specifications and they enhance the user's experience.

This joint effort allows us to create information that is relevant, timely, comprehensive and of the highest quality. The result is an interactive and friendly system that covers all the latest technologies.

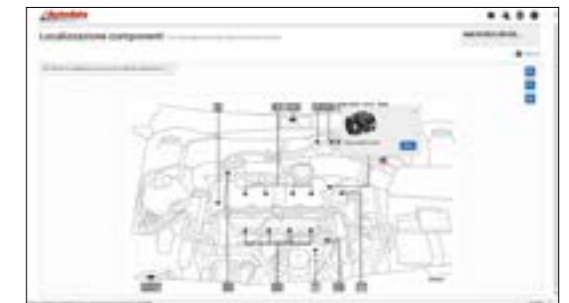

Search engine by driver



Control symbols

## PREMIUM Headlamp aligner 007935902020

A fully electronic device for checking the parameters of car lighting, equipped with a camera that allows any type of car headlight to be measured.

For a long time, car headlights performed the primary lighting function. The development of driver assistance systems has necessitated changes to car lighting systems. Designers of various car brands began to introduce and develop adaptive lighting systems which started to appear in premium cars. Nowadays, this type of solution is increasingly common in lower-end cars. For this type of lighting system, it is necessary to use a suitable device to allow proper control of the lighting. An incorrect inspection procedure may lead to a system malfunction. Magneti Marelli's Premium device makes it possible to measure the latest versions of car lighting as well as adaptive headlights such as Matrix, DLA and ILS headlights.

The integrated circuit used in the device allows precise measurement of the lighting, with the measurement result displayed on a LCD touch-screen. The results obtained can be presented in the form of a printout obtained thanks to the printer installed in the device. Thanks to the rotating measuring column, it is possible to adapt the device more easily to the headlight surface. The Class 3R laser on the column allows base points to be defined to facilitate the measurement of the light beam. An additional advantage is the placement of the cross laser in the measuring head housing, which allows the device to be centred with respect to the centre of the light source.

The electronic headlight alignment device is equipped with a camera to perform a full analysis of any type of headlight on any type of car.

### Technical data:

- the instrument has a rotating column which allows the measuring head to be accurately positioned in relation to the headlight
- the column is fitted with a balanced system to facilitate movement of the optical box
- injection-moulded plastic head housing incorporating a glass lens with a diameter of 230 mm, controllable deviation from the mechanical position of the light beam of 1cm/10m possible
- the measuring head is equipped with ports: RS232 and USB
- the base of the measuring instrument is made of an aluminium-steel alloy and is equipped with a levelling system
- the device is equipped with a printer
- touch screen
- proven method for positioning in relation to the vehicle: using a broadband laser beam, additionally the device can be retrofitted with laser positioning of the headlight centre (cross laser)
- Possibility to work via a laptop and print using the optional Headlight 4 software
- Display TFT colour touch screen: 5.7" 320x240 display
- CMOS camera 640x480 VGA - PIXEL 6.0 x 6.0µm
- Operating temperature +5°C - +45°C
- Humidity 20% - 80%

- Storage and transport
- Temperature -25°C - 45°C/-13°F - 113°F
  - Humidity 30% - 60%
- Dimensions and weight
- Dimensions (W x D x H) 660 x 695 x 1780 mm
  - Weight 35 kg (66 lbs)
- Scale
- Top and bottom alignment 0 - +/- 600 mm / 10 m (0; +/-6 %)
  - Right and left alignment: 0 - 1000 mm / 10 m (0; +/- 10 %)
  - Brightness 0 - 240 lx (0 - 150 000 cd)
  - Illumination intensity 0-150 000 lux
  - Height of the central optical point from ground level: 240 - 1450 mm
  - Power supply (internal battery) 12 V
  - Battery charger input voltage 100 - 240 V, 50/60 Hz
- Measurement accuracy
- Intensity +/- 5% end of scale
  - Vertical axis deviation +/- 0.1%
  - Horizontal axis deviation +/- 0.2%



### Unique features



## Advantages:

- The device fully measures the parameters of all types of lights, including: LED, bi-xenon, xenon, halogen and conventional, with reflectors: paraboloid, multi-paraboloid, projector, with a diffuser glass, with a smooth glass, equipped with an AFS system
- Headlight service for all type vehicles (European, British, American, Japanese, etc.).
- Available languages: Polish, English, Czech, Slovenian, Hungarian
- Communication protocols available: Net1, Net2, Giagnet, to be installed on request
- Software Update: using USB, RS232 connection



Rotating column  
170cm high

## SMART Analog headlamp aligner 007935902010

Analog headlamp aligner with digital lux meter.

### TECHNICAL DATA:

- column equipped with a counterweight, the operator can move the optical box in two directions by lightly touching it
- injection-moulded plastic head housing incorporating a glass lens with a diameter of 230 mm, controllable deviation from the mechanical position of the light beam of 1cm/10m possible
- The base of the measuring instrument is made of an aluminium-steel alloy and is equipped with a levelling system

Kod MM: 007935902010

### Unique features

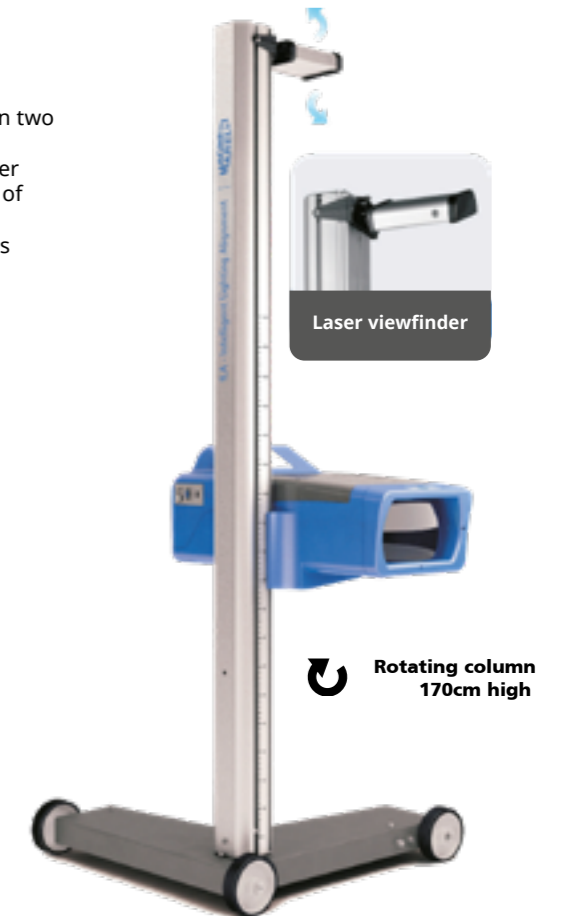

Laser viewfinder

Rotating column  
170cm high

## LOGIC Analog headlamp aligner 007935902030

### Technical data:

- Positioning with a mirror
- Height of column 172 cm
- 3 wheel stable base
- Optical box with a 200 mm diameter glass lens
- Precision adjustment system
- Digital display showing the result in candelas (kcd)

Kod MM: 007935902030



Positioning with mirror screen

Headlight lowering adjustment and vertical adjustment of the lens position

Display digital



All devices we offer measure in candelas [kcd] and are consistent with the latest interpretation of the requirements set out in point 4.1.7 of Annex 1 to the regulation of MTBiGM of June 26, 2012 (Journal of Laws, item 996) on the scope and the method of conducting technical tests and templates of documents used with these tests.



| EQUIPMENT AND FUNCTIONS                              | 007935902020 PREMIUM | 007935902010 SMART | 007935902030 LOGIC |
|--|----------------------|--------------------|--------------------|
| Digital lux meter                                    | +                    | +                  | +                  |
| Wide-band viewfinder                                 | +                    | +                  | +                  |
| Microprocessor-based measurement system              | +                    |                    |                    |
| Laser alignment of the device to the vehicle         | +                    | +                  |                    |
| Eccentric axis for tilt adjustment                   |                      | +                  | +                  |
| Digital tilt adjustment                              | +                    |                    |                    |
| Swivel column to orient the optical box              | +                    | +                  | +                  |
| Can be mounted on rails                              | +                    | +                  |                    |
| Touch screen with 5.7" resolution                    | +                    |                    |                    |
| Support for LED, MATRIX headlights                   | +                    |                    |                    |
| USB interface  | +                    |                    |                    |
| RS232 interface                                      | +                    |                    |                    |
| Bluetooth compatible                                 | +                    |                    |                    |
| Compatible with HEADLIGHT 4 software                 | +                    |                    |                    |
| Possibility to mount a printer                       | +                    |                    |                    |
| Preparation for WLAN                                 | +                    |                    |                    |
| Upgradability  | +                    |                    |                    |
| Calibration possible with manufacturer's calibration | +                    | +                  | +                  |
| Base on plastic wheels                               | +                    | +                  | +                  |
| Fresnel lens   | +                    | +                  | +                  |

| CODE MM      | ACCESSORIES   |
|--------------|---|
| 007935902050 | Double guide rails  |
| 007935902055 | Single guide rail   |
| 007935902060 | Height sensor for headlights for Smart and Premium devices      |
| 007935902070 | Bluetooth master-slave kit (no Bluetooth on the computer)       |
| 007935902080 | Single Bluetooth module (the computer has its own Bluetooth)    |
| 007935902090 | Printer for the headlight alignment device to the Premium model |
| 007935902110 | OFFLINE CTF6 software update for the Premium model              |
| 007935902120 | ONLINE CTF6 software update for the Premium model               |
| 007935902130 | Headlight 4 software for the Premium device                     |

## Master Alt 2 007935063030

The device can be used to diagnose the charging circuit in cars with:

- alternator charge current provided by the ECU
- control standards COM - LIN, BSS (BSD), SIG, P-D, L-RVC, RLO
- generates currents resembling the actual conditions
- to test the alternators installed in vehicles



### General characteristics:

The device can be used to diagnose the charging circuit in cars with alternator charge current provided by the ECU. The device generates currents resembling the actual conditions for the voltage regulators in the car. The device is designed to test the alternators installed in vehicles or on testing tables as well as the regulators alone - with a standard testing device. The device can provide the information on whether the voltage regulator can correctly communicate with the car's ECU and if it responds to required parameters ap

### Compatible control standards:

- ▶ COM - LIN, BSS(BSD) interfaces
- ▶ SIG - FORD
- ▶ P-D - Mazda
- ▶ L-RVC - GM
- ▶ RLO - Toyota

### Device operation

The test subject selection menu will appear. Select the required parameter the up and down arrow keys and press OK what moves in the test mode.

After pressing the knob, the display will present the following information:

- ▶ voltage of the tested circuit (large digits)
- ▶ required voltage (small digits on the top of the display)
- ▶ alternator load DF/DFM [%]

## Annual update to the tester Master Alt with NFC function

007935063060



## Alt Diag Pro - alternator bench

007935063050

The Alt Diag Pro is a test bench that allows you to check the alternator or starter performance. This device evaluates the measurement results helping to diagnose damaged system components that may occur in particular test assemblies of the alternator or starter. Our test bench is mainly used for testing alternators of 12V and currents up to 300A and alternators of 24V and currents up to 150A as well as for testing starters with similar parameters.

### Supported interfaces for communication with the alternator:

- ▶ COM (LIN, BSS),
- ▶ C,
- ▶ SIG, a
- ▶ RLO,
- ▶ L-RVC
- ▶ LAMP.

**Load  
up to 300 A**

### The following types of automated alternator testing are supported:

- 1) Standard, which allows to record the maximum current under load, not exceeding the determined value during the test.
- 2) Efficiency, which give the maximum load current without imposing any restrictions, checking the alternator under load under extreme conditions.

### Parameters of use:

- ▶ Electric power supply - 400V with a frequency of 50Hz at rated current 16A in a system with 3P + N + PE leads. 3.3
- ▶ Compressed air supply via pneumatic 1/2" coupling, ensures proper and secure tension of the V-belt.
- ▶ Touch screen that allows, among others, changes in configuration and position settings while also providing comfortable control conditions and clarity of displayed information and messages along with parameter under analysis.

### Parameters that can be measured and analyzed by a user:

- ▶ maximum power of the starter,
- ▶ maximum starter current (starting current),
- ▶ average starting voltage
- ▶ average starting current



### Parameters to be analyzed by Alt Diag Pro bench:

- ▶ graph of current ripple,
- ▶ maximum alternator current,
- ▶ alternator leakage current,
- ▶ Voltage Set Point,
- ▶ turn on speed,
- ▶ DFM value,
- ▶ performance curve,
- ▶ maximum power of the alternator,
- ▶ WINDING value.

### Alt Diag Pro features:

- ▶ Compact size 80 [cm] x 70 [cm] x 110 [cm]
- ▶ Possibility of testing alternators with interfaces: LIN, BSS, SIG, RLO, RVC, C
- ▶ DFM signal reading (M, FR, DF, LI, F)
- ▶ 8.5 hp engine
- ▶ Operation of 12 and 24 V alternators and starters
- ▶ Maximum alternator load 300 A
- ▶ Built-in oscilloscope for measuring ripple current
- ▶ Detect damaged diodes and stators
- ▶ Possibility to run fully automated test for alternators
- ▶ Basic diagnostic function of the starter
- ▶ Pneumatic belt tension of alternator
- ▶ Includes plugs and adapters for fixing different types of alternators
- ▶ Industrial touch screen (possibility to work wearing gloves)
- ▶ Automatic test results recording
- ▶ Possibility to print the test run
- ▶ Rich alternator base
- ▶ Option to update the table via USB

## Alt Diag Pro software update

007935063070

NEW

## POWER M120A

007950007100

### 120 AMP MULTI-PURPOSE BUFFER BATTERY CHARGER

The POWER M120A multi-purpose charger is designed to charge all types of batteries, including: lead acid, maintenance-free, standard, gel, nonwoven, AGM, EFB and lithium-iron-phosphate (LFP). POWERM120A will automatically charge deeply discharged batteries with a 6 (LFP) or 8 step deep discharge recovery program. It has a power backup function to buffer data (e.g. radio, controller, etc.) during battery replacement („Memory Saver“) and a buffer charging mode that maintains battery charge and electrically stabilises the vehicle's electric system when the engine is turned off. In buffer mode, the charger can supply power to the vehicle's controllers, e.g. during firmware updates, recalibration or configuration, which proves highly useful in Pass Thru procedures.



### TECHNICAL SPECIFICATIONS

|  |  |
|--|--|
| Max. charging current: -12 V 120 A   | Standard charging with Desulfation, battery excitation and diagnostics 12.0-14.8 V, max. 100 A   |
| Battery capacity: 20-400 Ah  | 12 V Lead Acid, 12 V AGM Flat/Spiral, 12 V EFB 12 V VRLA/GEL, 12 V EFB 12 V VRLA/GEL, 12 V Lithium (LiFePO4). Capacity of charged batteries: 20-400 Ah |
| Charging cables length: 2 x 5 m  | Operating temperature range: -0°C - +50°C  |
| Charging cable cross-section: 25 mm <sup>2</sup>                           | Power supply voltage: 230 V, 50/60 Hz  |
| Power consumption: 1600 W max  | Nominal battery voltage: 12 V  |
| Weight (without power supply and power cable): 6.6 kg                      | Protection class: IP20   |
| Backup charging - „Showroom“ mode: 12.0-13.2 V max. 50 A                   | Temperature compensation: Yes  |
| Modifiable buffer charging: 12.0-14.8 V, max. 120 A (20 A input)           | Ripple < 200mVpp Dimensions (L x H x W): 254 x 370 x 110 mm  |
| Backup power supply for battery changes - „Memory Saver“ mode 12.9 V 3-30A | Weight: 6,2 kg   |

### SHOWROOM MODE

- ▶ For long term power backup - in showroom vehicles
- ▶ With a height of only 110 mm, it can easily be placed under the vehicle
- ▶ Lock mode

### MEMORY BACKUP MODE

- ▶ When connected to terminals, the charger maintains appropriate power supply to systems, preventing loss of settings and/or generating errors when vehicle battery is disconnected

### INCLUDED

- ▶ Battery charger
- ▶ Detachable charging cables: 2 x 5 m
- ▶ Power supply cable
- ▶ Wall mount: 4 pcs.
- ▶ Operating manual
- ▶ Safety instructions

### Memory Saver Ms-7E

007950006920

#### Key features:

- ▶ Device designed to support the controller memory when the car battery is disconnected.
- ▶ Very useful for replacing the battery
- ▶ Prevents data loss and reset of all devices.
- ▶ Connection to the vehicle through the EOBD socket or lighter connector.
- ▶ With the LED control panel it is possible to monitor the internal state of the battery on the fly.

#### Technical data:

- ▶ Battery installed inside: AGM
- ▶ Voltage: 12V
- ▶ Battery capacity: 7 Ah
- ▶ Dimensions: 24.5 cm x 24.5 cm x 18 cm
- ▶ Weight: 3 kg



# EASY BAT

## 007935660670

### Compact 12V and 24V battery tester

Compact 12V and 24V battery tester  
 EASY BAT is a compact 12V and 24V battery tester characterised by its small dimensions, simple and intuitive operation and interesting design. It can be used for testing 12V and 24V batteries. It allows easy and quick verification of the charge level of the battery itself, as well as checking the correct operation of the charging system. The test results are presented on an easy-to-read display and can be printed out if required, using the built-in thermal printer.

#### Application:

- ▶ Battery test 12V, 12V Start-Stop
- ▶ System test 12V, 24V
- ▶ Internal resistance reading
- ▶ Supported battery types:  
Flooded, VRLA/GEL, FRB, AGM S, AGM F
- ▶ Supported measurement standards:  
CCA/SAE, CA/MCA, EN, JIS, DIN, IEC
- ▶ Measuring range: 40 to 2000 CCA
- ▶ Cable length: 0.8 m
- ▶ Temperature compensation: Yes, manual.
- ▶ Thermal printer: Yes
- ▶ Display: 4 lines with adjustable brightness
- ▶ Operation: keypad (left/right/Enter)
- ▶ Internal power source: CR2032 x 1
- ▶ Operating temperature: 0-50°C
- ▶ CE and UKCA certified
- ▶ Dimensions: 250 x 130 x 45 mm
- ▶ Operational languages: PL, EN, FR, DE, ES, IT, PT, NL, RU, TR, CZ

#### Technical data:

- ▶ Cable length: 0.8 m
- ▶ Temperature compensation: Yes, manual.
- ▶ Thermal printer: Yes
- ▶ Display: 4 lines with adjustable brightness
- ▶ Operation: keypad (left/right/Enter)
- ▶ Internal power source: CR2032 x 1
- ▶ Operating temperature: 0-50°C
- ▶ CE and UKCA certified
- ▶ Dimensions: 250 x 130 x 45 mm
- ▶ Operational languages: PL, EN, FR, DE, ES, IT, PT, NL, RU, TR, CZ

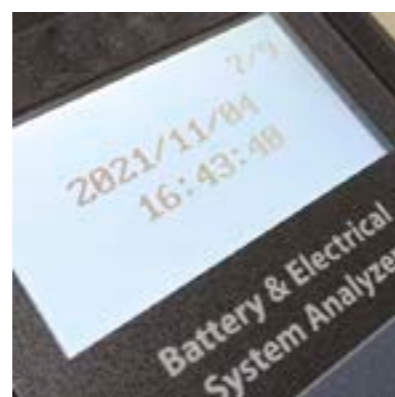

# BAT EXPERT PRO 2.0

## 007935660660

### Universal 12V and 24V battery and charging system tester

#### Battery and charging system tester Magneti Marelli

Bat Expert 2.0 from the Magneti Marelli offer is a universal tester that allows you to check the condition of both the battery itself and the components cooperating with it - the alternator and the starter. All operations, as well as the printout itself, can be presented in Polish.

#### BATTERY TESTS:

- ▶ current voltage
- ▶ starting current
- ▶ graphical percentage of the battery condition and its charge level.
- ▶ battery recommendations (charge, replace, replace urgently)
- ▶ possibility of uploading all data to a special database on a PC and archiving tests
- ▶ unique slope battery test function

#### ALL TESTS CAN BE PERFORMED ON BATTERIES:

lead-acid, gel, AGM (maintenance-free),  
 VRLA (partially maintenance-free): Start&Stop, SLI (standard).  
 The starting current can be specified according to one of the standards:  
 SAE, EN, EN2 IEC, DIN, EFB, CA/MC and JIS.

#### TESTS IN THE VEHICLE:

- ▶ voltage drop during start-up
- ▶ charging test without load (checking the alternator and voltage regulator)
- ▶ charging test under load (also checking the efficiency of on-board electrical appliances)
- ▶ voltage stability test (checking the voltage regulator and alternator diodes)
- ▶ battery internal resistance test

#### Printer:

All tests performed using MM Bat Expert 2.0 can not only be viewed on a large and clear display equipped with backlight adjustment, but also immediately printed using the built-in printer. This printout contains all the data checked during the test, giving the customer full information about the condition of the battery, alternator and voltage regulator. MM Bat Expert 2.0 is a device that is exceptionally easy to use and user-friendly. All available tests are performed step by step, according to the instructions provided by the tester on the display. Everything can also be archived in a dedicated database accessible via PC and connected to the device via a USB-C cable.

#### ADVANTAGES:

- ▶ menu available in 19 languages - English, French, Spanish, German, Italian, Portuguese, Polish, Czech, Greek, Turkish, Croatian, Romanian, Hungarian, Russian, Bulgarian, Lithuanian, Slovenian, Dutch, Danish.
- ▶ color TFT LCD display
- ▶ durable and handy housing
- ▶ easy-to-read backlit display
- ▶ checking the status of 6V and 12V batteries
- ▶ 12V Start-Stop battery condition check
- ▶ measurement of voltage, starting current and diagnosis of battery condition
- ▶ compatibility with most types of batteries available on the market
- ▶ wide range of starting currents of tested batteries:  
40 - 2100 (EN) 25-3000 CCA
- ▶ control of voltage spikes and alternator efficiency in various conditions (for 12V and 24V systems)
- ▶ printer enabling printing of test results

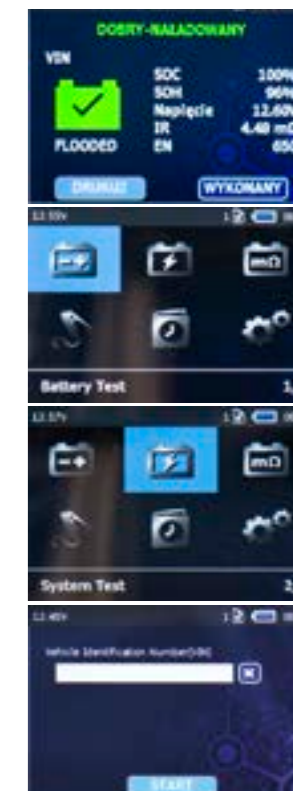

# Battery Charger BAT 100 10A with LCD

007950007100

Device for charging batteries and for battery maintenance in motor vehicles. Simple operation is ensured by the LCD display with a graphical representation of the battery charge level, which is achieved through intelligent multi-stage charging (9 cycles). The charger handles all standard battery types including the latest lithium polymer, providing adaptability to each type by charging in three modes, including batteries intended for motorcycles, passenger cars and voltage suppressors.



- ▶ Temperature sensor with compensation function
- ▶ Operating temperature: -20 do +50°C
- ▶ Weight 880g

**Dimensions:**  
▶ Length: 210 mm  
▶ Width: 98 mm  
▶ Height: 60 mm

**Technical parameters:**

- ▶ LCD display
- ▶ Includes a set of ring clamp
- ▶ AC voltage: 220-240V, 50-60Hz
- ▶ Minimum battery voltage: - Acid-lead: 2V - LFP: 10V
- ▶ 3 charging modes: - Smaller batteries: 1.5A-12V; 2.3Ah to 30Ah

- Large batteries: 10A-12V; 30Ah to 200Ah
- Power supply: 13.6V - 10A
- ▶ 9 cycles for batteries AGM, GEL, STD, VRLA, MF, CAL/CAL
- ▶ 6 cycles for LiFePO4 battery
- ▶ Supported batteries: 12V - AGM, GEL, STD, VRLA, MF, CAL/CAL
- ▶ Intelligent charging program



**Digital battery load tester BAT508**  
007950007020

Digital 12V battery load tester. It runs tests of charging degree, start-up abilities, efficiency of charging system and start-up tests.

**The tester is equipped with:**

- ▶ LED display showing voltage and test results
  - ▶ automatic load stopping after 10 seconds and maintaining the voltage
  - ▶ unique 3-stage reading: checking polarization on the LCD screen, control of battery charging level, reading the test of charging system
  - ▶ control of battery and charging system conditions
  - ▶ total transfer possibility.
- No need to connect external power supply.**



**125 A Hand held battery load tester BAT601**  
007950007030

The BAT 601 is designed for 6V and 12V batteries up to 1000CCA. Performs tests of charge, boot and charging performance. Used for standard and maintenance -free batteries in passenger cars and delivery vehicles. The tester is completely portable. No need to connect external power. Performs a complete test in 10 seconds. The device is sure and accurate. Robust and shockproof. It has durable, color-coded clamps.

**Supported batteries:**

- ▶ 6V
- ▶ 12V

**Possible operations:**

- ▶ Load test
- ▶ Temperature Correction (1 step = 50A)
- ▶ Testing the charging system
- ▶ Starter test (12V)



007935660650



**Classified Protection**  
IP65 Complete protection against contact, from infiltration of dust and water projected from a nozzle.

# Battery charger BAT-5 PRO

It is a compact microprocessor charger with intelligent charging function. Affordable price and small size combined with high functionality, they guarantee professional battery regeneration. Safety: IP65 - dust resistance and moisture, protection against reverse polarity connection/sparking; overcharge protection battery and protection against short circuits.

- Easy:** Bright LEDs identify accurate status charging.
- Weight:** Lightweight, portable design and compact structure.
- Charges:** 6V & 12V lead-acid batteries, Start-stop EFB, Start-stop AGM, WET, MF, Ca/Ca, AGM and GEL 12V LiFePO4 battery
- Input:** AC 220-240V/1A/50Hz
- Charging output mode:** 4A
- Output maintenance mode:** pulse charging
- Cables:** 183 cm
- Dimensions:** 172.97(L) x 89.91(W) x 45.89(H) mm(approx.)
- Weight:** 0.85 kg.



The professional MAGNETI MARELLI charger provides five-stage charging automatic, which will not only effectively charge the batteries, but also will extend the operational life necessary for batteries. Deep discharge recovery and a temperature sensor are just some of the many advantages.

## 5 charging stages

- 1 Desulfation** - Focuses on heavily discharged or slightly sulfated batteries that exhibit low voltage and are resistant to activation. The MAGNETI MARELLI charger starts pulsed (pulse) charging to charge the battery until the voltage is restored and reaches the expected level after charging. The purpose of this stage is to save excessively discharged or slightly sulfated batteries and regenerate them.
- 2 FAST CHARGING** - When the battery voltage is higher than the set level, the MAGNETI MARELLI charger applies a high charging current to quickly charge the battery until it reaches up to 75% charge. The goal of this stage is to charge the battery as quickly as possible, in the most efficient way possible.
- 3 CORRECTION AND ANALYSIS** - When the voltage reaches the maximum safe value (predefined), the MAGNETI MARELLI charger will automatically stop continuous fast charging and start impulse charging of the battery with a lower current. The purpose of this step is to fully charge the battery in a safe manner.
- 4 CHARGING TO MAXIMUM STATE** - turn off During this stage, the MAGNETI MARELLI charger will turn off automatically when the battery is 100% charged. The charger will continuously monitor the battery voltage to decide whether to deliver a new charge or not. The purpose of this stage is to fully charge the battery without overcharging it.
- 5 Maintenance** - If the voltage drops below the pre-set level due to self-discharge of the battery, the MAGNETI MARELLI charger will start pulse charging at a low current to maintain the battery's fully charged state. The cycle repeats until the charger is in Maintain floating mode.

## Desulfation, fast charging, leveling, filling, maintenance

- |  |  |  |   |  |
|--|--|--|---|--|
| <b>1 Desulfation</b><br>An impulse to regenerate a sulphated battery | <b>2 fast charging</b><br>Loading battery in no time | <b>3 alignment</b><br>Analyzes battery | <b>4 filling</b><br>Mode battery monitoring | <b>5 maintenance</b><br>Maintains optimal battery charge |
|--|--|--|---|--|

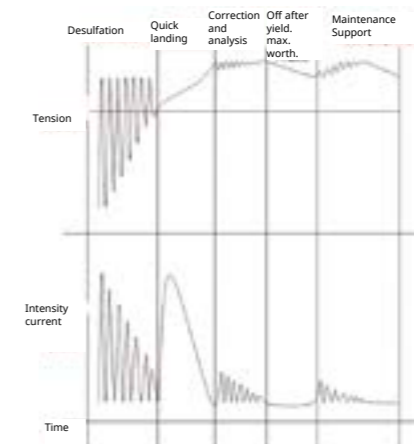

## Magneti Marelli ES.3 Diesel & gasoline engine treatment unit

007935104650

### Device operation:

The ES.3 device guides the user step by step through the fuel system cleaning cycle. Informations are displayed on the LCD screen. Automatic operation mode that does not require mechanical intervention during the procedure of cleaning. Fuel pressure generated by the device is automatically adjusted to the pressure in the vehicle's fuel system. Power is supplied from a serviced vehicle - 12V.

### Device characteristics:

Automatic cleaning device for gasoline and diesel fuel systems in:

- ▶ motorcycle
- ▶ passenger cars
- ▶ light duty trucks
- ▶ heavy duty trucks
- ▶ buses
- ▶ marines

### Supported systems:

- ▶ Common-Rail
- ▶ Conventional Diesel
- ▶ Gasoline Direct Injection (G-DI, FSI, HPI, etc.)
- ▶ Conventional Fuel Injection (MPFI / TBI / CIS)
- ▶ Carburator
- ▶ LPG



### ACCESSORIES

Exclusive Fuel System Adapters Kit (Quick Connectors) / Available For All Types of Engines Configurations / ES Series & FST Tools

007935101460



Cleaning Fluid for DPF filters for ES.3 - 2 L

007935101670



Cleaning Fluid for ES.3 (pack of 24 pieces)

007935095490



Set of adapters for DPF cleaning for ES.3

007935100530



Intake Manifold Cleaning Adapters Kit / ES Series

007935101470



## OXHYDRO Carbon Cleaner

007935200100

Innovative solution for cleaning combustion residues from the engine

### APPLICATION: BENEFITS

The oxyhydrogen mixture produced by the device is introduced into the intake duct, mixing with the air drawn in through the filter. Its action starts in the combustion chamber, where, through a chemical process of pyrolysis that raises the combustion temperature,

it removes all residues from: piston head, cylinder, injector nose, valves, spark plugs, glow plugs, etc. without heating the metals, as the heat is concentrated in the exhaust gas. This heat, together with the moisture from the combustion of the gas, is expelled with the exhaust

gas, which is decarbonised after passing through: EGR valve, turbocharger, lambda probe, catalytic converter and FAP/DPF.

### DECARBONISATION AND CLEANING OF THE ENGINE

There are a number of reasons why carbon residues build up in a vehicle's engine. With HHO technology, the vehicle's performance can be restored easily, quickly and in an innovative way. The oxyhydrogen mixture has a remarkable cleaning capacity. In fact, electrolysis generates a gas that enables all sensitive engine parts to be cleaned in a matter of minutes.



Compatible with all diesel, petrol, LPG and methane engines.

- ▶ More power
- ▶ Reduced consumption
- ▶ Lower emissions and exhaust smoke

CAPACITY  
700 l/h



10-inch colour display



Mini VCI OBD



Dropper and dosing tube



Remote control programme

### FEATURES

- ▶ Dimensions: 68 x 110 x 50 cm
- ▶ Power supply: 220-240 V 50 Hz 16 A
- ▶ Power: 3500 W

- ▶ Display: 10" touchscreen
- ▶ Connection: Wi-fi / Bluetooth
- ▶ Generator: AISI 316L steel
- ▶ Weight: 120 Kg (empty tank)

- ▶ Tank capacity: 60 litres
- ▶ Consumption: 1.5 l/h
- ▶ Area of application: cars/motors/trucks/agricultural vehicles/boats.

## Gasoline injectors tester Magneti Marelli GS2/GS4

### Device characteristics:

Automatic device for testing petrol injectors, including:

- ▶ Multi-point MPI injection
- ▶ Single-point TBI injection
- ▶ HPI, FSI direct injection, GDI in the low pressure range
- ▶ LPG
- ▶ CNG

Thanks to the GS series devices, it is possible to detect the causes of incorrect engine operation:

- ▶ Increased exhaust emission
  - ▶ Reduced engine performance (power, torque)
  - ▶ Increased fuel consumption
  - ▶ Failure of direct injection systems (leaks, pressure drop)
  - ▶ "Hard" engine idling, engine stalling
  - ▶ Problems with the engine starting
- Thanks to the use of illuminated (high brightness LED diodes) measurement tubes it is possible to observe and evaluate:
- ▶ Uniformity of the injected fuel jet
  - ▶ The shape of the fuel stream
  - Amount of fuel - iVM test.
  - ▶ (with an accuracy of  $\pm 1\text{ml} / 130\text{ml}$ )

### Features:

- ▶ Operating pressure: 0-10 bar
- ▶ Gasoline Direct Injectors tested up to 10 Bar
- ▶ Fully programmable Test-Plans
- ▶ Variable & Customizable
- ▶ Test-Plans
- ▶ Engine load Simulation Tests
- ▶ Ergonomic and dynamic and user-friendly design
- ▶ Short testing time required / Automatic function
- ▶ Ergonomic, robust, fast & simple injector clamping
- ▶ Spray and Volume test
- ▶ Injector Protection circuit
- ▶ Injector Reverse flush after
- ▶ U/Sonic cleaning



### STANDARD EQUIPMENT:

Standard Kit  
Set of Fuel Rail & Adapters for all makes and types of Top-Feed Injectors



Reverse flushing



Injection volume metering



Software



Gasoline injector calibration fluid, ultrasonic solvent



Ultrasonic bath

### Exclusive adapter set GS2/GS4

Exclusive set adapters for all top-powered ones and side injectors petrol, and CNG and LPG

**007935100475**

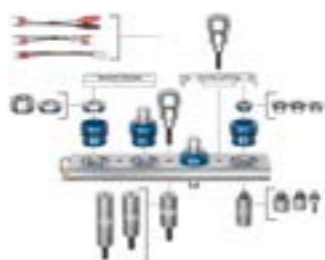

## GDRX injector tester Magneti Marelli 007935105960

State-of-the-art device for testing direct petrol injection systems (G-DI, FSI, HPI, JTS). The GDRX series, is characterised by its compact design and very intuitive operation. With a maximum operating pressure of 450 bar, they allow tests to be carried out on virtually all injectors on the market.

### Device characteristics:

- ▶ Test of all types of electromagnetic and piezo injectors
- ▶ EU6 injector test with signal energy control
- ▶ Operating pressure up to 450 bar Electronic measuring system - dynamic XKM dose measurement
- ▶ Unique PIEZO stack regeneration function
- ▶ Free database update
- ▶ Operation in automatic mode
- ▶ Built-in 8" Android tablet
- ▶ Clearly presented and printable test results
- ▶ Adapter sets available to power all types of injectors, testing time per injector - 5-7 minutes

New operating programme with new features, including detailed description of the connection, possibility of creating a handy database. The ability to configure the device in the cloud, giving you access to reports, the current status of tester use and many other features.

### GDRX accessory packages:

| X-Pack1 | ----         | GDI.ADAPTER-S-KIT.01, GDI. WIRES-KIT.01          | S |
|---------|--------------|--|---|
| X-Pack2 | 007935105480 | UPL.10, BFK.01, GDI LP-KIT.02, RSP, GDI1x-sh.RSP | O |

S - standard / O - option



## GDU4RX injector tester Magneti Marelli 007935104570

The most advanced device on the market for testing any petrol direct injection system. With a maximum operating pressure of 650 bar, they allow tests to be carried out on all injectors on the market. VDO injector coding activation option available

### Device characteristics:

- ▶ Test of all types of electromagnetic and piezo injectors
- ▶ Operation of 4 injectors
- ▶ Working pressure up to 650 bar
- ▶ Electronic measurement system - dynamic XKM dose measurement
- ▶ Unique PIEZO stack regeneration function
- ▶ Free database update
- ▶ Operation in automatic mode
- ▶ Built-in 10" Android tablet
- ▶ Clearly presented and printable test results
- ▶ Adapter kits available to feed all types of injectors
- ▶ SIEMENS BMW injector coding function

GCC.06 (MM 007935103520) - SIEMENS BMW injector coding function - one-time software activation, for GDU4RX and GTB4RX.

### GDU4RX accessory packages:

|         |              |   |   |
|---------|--------------|---|---|
| X-Pack1 | ----         | (GDI.ADAPTER-S-KIT.01, GDI. WIRES-KIT.01 ) x4; UPL.11x1 | S |
| X-Pack2 | 007935105440 | GCC.06x1, GDU4rX-sh. RSP-1/2, GDU4rX-sh. RSP-3/4, RSPx4 | O |
| X-Pack3 | 007935105480 | (BFK.02, GDI LP-KIT.01, UB-15E, Y4L) x1, EXT.50x4       | O |

S - standard / O - option

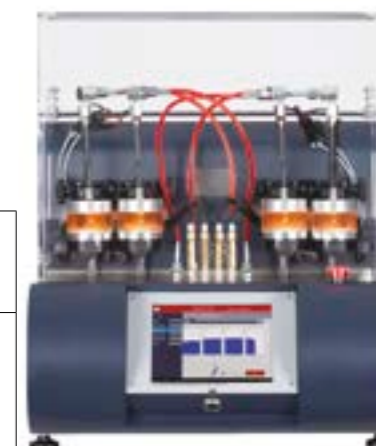

## GTB4RX injector tester Magnetit Marelli

GTB4RX air (MM: 007935104550)  
GTB4RX water (MM: 007935104560)

The latest GDI injection tester on the market. Professionals looking for advanced technology and broad application possibilities will particularly appreciate the device's capabilities. The GTB4RX test stand is a completely self-contained, free-standing, power-driven unit suitable for pressures up to 1,200 bar. The unit can handle all GDI injection systems. The GT- B4RX test bench is available with an air or water (mains connection required) cooling system.

With the GTB4RX series, it is possible to generate new codes for SIEMENS BMW injectors. In addition, it is possible to carry out a regeneration procedure for the piezo element in piezo injectors. Extensive database for all types of injectors. Free automatic software updates via Wi-Fi.

### Device characteristics:

- ▶ Test of all types of electromagnetic and piezo injectors
- ▶ Operation of 4 injectors
- ▶ Working pressure up to 1200 bar
- ▶ Electronic measurement system - dynamic XKM dose measurement
- ▶ Unique PIEZO stack regeneration function
- ▶ Free database update
- ▶ Operation in automatic mode
- ▶ Built-in 15" Android tablet
- ▶ Clearly presented and printable test results
- ▶ Adapter kits available to feed all types of injectors
- ▶ SIEMENS BMW injector coding function

### GDU4RX accessory packages:

|         |              |   |   |
|---------|--------------|---|---|
| X-Pack1 | ----         | (GDI.ADAPTER-S-KIT.01, GDI.WIRES-KIT.01)x4, UPL.11x1    | S |
| X-Pack2 | 007935105360 | GCC.06x1, RSPx4, GTB4rX-sh.RSP-1/2, GTB4rX-sh.RSP-3/4x1 | O |
| X-Pack3 | 007935105370 | (BFK.02, GDI LP-KIT.01, UB-15E, Y4L)x1, EXT.50x4        | O |

S - standard / O - option



## Accessories for petrol injector testers:



## ELECTRIC VEHICLE OPERATION



## EVCheck 1000 / EVCheck 800 tester

007935013940 / 007935013950

The **EVCheck 1000** and **EVCheck 800** testers have been developed for the diagnosis of high-voltage ni- kel metal-hy- dride and lithium-ion battery modules found in hybrid and electric vehicle brands such as: Toyota, Lexus, Honda and other manufacturers. The EVCheck 1000 allows simultaneous verification of up to 36 modules (EVCheck 800 up to 12 modules) consisting of 3 to 12 cells.

With the EVCheck 1000 or EVCheck 800 tester, it is possible to equalise the capacity of the cells by discharging and charging them to a specific voltage with high accuracy. During the diagnostic process, the tester stops charging the module where the temperature has exceeded a certain value. The devices are additionally equipped with short-circuit and polarity reversal protection. The battery diagnostic process runs in automatic mode. The process is controlled and monitored on the touch screen.

The diagnostic result is stored in the tester's memory, allowing a copy to be made to a USB memory stick.

### Advantages:

- ▶ automatic test mode
- ▶ battery protection against overheating
- ▶ simple and intuitive menu
- ▶ free software updates
- ▶ saving diagnostic results



### Technical characteristics

|                               | EVCheck 800  | EVCheck 1000 |
|-------------------------------|--------------|--------------|
| Supply voltage, V             | 230          |              |
| Mains type                    | Single-phase |              |
| Maximum power consumption, kW | 1,2          | 3,5          |
| Dimensions (LxWxH), mm        | 640x320x225  | 1430x300x220 |
| Weight, kg                    | 20           | 53           |
| Touch control                 | dotykowe     |              |
| Display                       | 9"           |              |

### Battery diagnostics (NiMH/NiMh)

|                                       | EVCheck 800                                 | EVCheck 1000                                |
|---------------------------------------|---|---|
| Number of test channels of the module | 12  | 36  |
| Charge current, A                     | od 0,1 do 4,5                               |   |
| Discharge current, A                  | od 0.1 do 5<br>(limited to 50W per channel) | od 0,1 do 6<br>(limited to 50W per channel) |
| Parameters measured                   | capacity, voltage, current, temperature     |   |
| Measurement accuracy:<br>voltage      | 0,02%                                       |   |
| current                               | 0,50%                                       |   |

### Additional features

|                           |  |
|---------------------------|--|
| Protection against        | - change of polarity<br>- hort circuit of connected wires<br>- overheating |
| Saving diagnostic results | Available  |
| Software update           | Available  |

## Lifting trolleys for engines and batteries

### MM E-LIFT 1.2 - HV battery lift 1.2t

007935013840

### MM E-LIFT 1.0 - HV battery lift 1t

007935013845

Special trucks equipped with a liftable and adjustable platform with a load capacity of 1,000 or 1,200 kg. They allow the operator easy access to the underside of the vehicle to remove the battery pack, engine and gearbox. Equipped with a remote control for convenient and safe operation and electrical isolation.

| Model            | MM E-LIFT 1.2 | MM E-LIFT 1.0 |
|------------------|---------------|---------------|
| Lifting capacity | 1200 kg       | 1000kg        |
| Lifting height   | 180 cm        | 180 cm        |
| Minimum height   | 80 cm         | 45 cm         |
| Platform length  | 175 cm        | 130 cm        |
| Platform width   | 80 cm         | 90 cm         |
| Power supply     | 230V          | 230V          |



007936347100

### High-voltage insulation tester

A simple and powerful tool that allows for:

- ▶ DC/AC voltage measurement
- ▶ Resistance measurement
- ▶ Insulation test

The ideal diagnostic device for reliable assessment of the technical condition of batteries and electrical systems fitted to hybrid and electric cars.



### TECHNICAL SPECIFICATIONS

- ▶ Complies with IEC/EN 61010-1 standard 1000V CAT III 600V CAT IV
- ▶ Voltage: DC 1000 V - AC 750 V
- ▶ Voltage for insulation test: 50 V, 100 V, 250 V, 500 V, 1000 V
- ▶ Insulation short-circuit test current nominal 1.8 mA
- ▶ Insulation measurement range: 0.01 MΩ to 10.0 GΩ
- ▶ Power supply: 6 AA batteries (not supplied)
- ▶ Dimensions: 180 mm x 140 mm x 65 mm
- ▶ Weight: approx. 900 g (without battery)

# Repair tool kit for hybrid and electric vehicles

007935655020

- Tool case**
- ▶ With profiled internal partitions
  - ▶ Dimensions 375x305x55 mm



## KIT COMPONENTS



### Insulated sockets, ratchet and extension

- ▶ Category up to 1000V AC and 1500V DC IEC 60900
- ▶ PVC insulation in orange, with laser marking
- ▶ 6 pieces 3/8" insulated sockets, sizes 8/10/11/12/13/14 mm
- ▶ Insulated 3/8" double-action ratchet, 203 mm long
- ▶ Insulated 3/8" extension piece, 140 mm long



### Protective helmet with visor

- ▶ UV-stabilised high-density polyethylene (HDPE) helmet, extremely resistant, insulated up to 1000V AC or 1500 VDC.
- ▶ Compliant with Regulation (EU) 2016/425 as amended and meeting the requirements of EN397, EN50365, EN13463, it has been classified as Category III PPE.
- ▶ Push-Key 4-point harness with fabric straps adjustable via zipper for high stability
- ▶ Built-in holes for face protection attachment
- ▶ Rear adjustment using a point tape from 52 to 62 cm



### Insulated open-end wrench

- ▶ Category up to 1000V AC and 1500V DC IEC 60900
- ▶ Insulated open-end wrench, size 10 mm



### Insulated Phillips screwdriver

- ▶ Category up to 1000V AC and 1500V DC IEC 60900.
- ▶ Insulated Phillips screwdriver 2x6x100 mm, length with handle 218 mm



### Insulated bent pliers

- ▶ Category up to 1000V AC and 1500V DC IEC 60900
- ▶ Pliers 200 mm



### Insulated flathead screwdriver

- ▶ Category up to 1000V AC and 1500V DC IEC 60900
- ▶ Insulated flathead screwdriver 1x5.5x125 mm, length including handle 232 mm IEC60900



### Insulating gloves

- ▶ Category III Class 0 (EN60903:2003/IEC60903:2014)
- ▶ Made from 1.6 mm thick natural latex rubber



### Insulation mat

- ▶ Nominal length, width and thickness: 100x100x0.4 mm

## +hybrid electric

### 0079510240555 SERVICE STATION MARKING KIT

It contains the materials needed to create an area where hybrid and electric cars can be repaired.

#### THE KIT INCLUDES:

- ▶ Wall sticker 750x50 cm
- ▶ Floor stickers 300x10cm 10 pcs.
- ▶ Floor stickers 300x20.4 cm
- ▶ Warning posts 90 cm 8 pcs.
- ▶ Red and white chain, 20 m

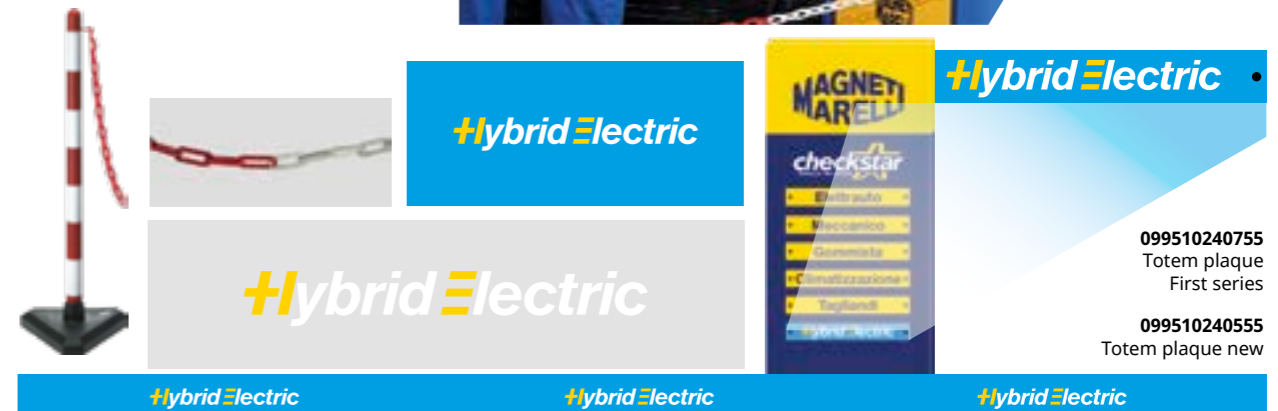

099510240755  
Totem plaque  
First series

099510240555  
Totem plaque new

## MAGNETI MARELLI TRAINING

- ▶ On-site training
- ▶ Online training available at [www.magnetimarelli-campus.com](http://www.magnetimarelli-campus.com).
- ▶ Monographs on hybrid and electric cars
- ▶ PES-PAV-PEI certification



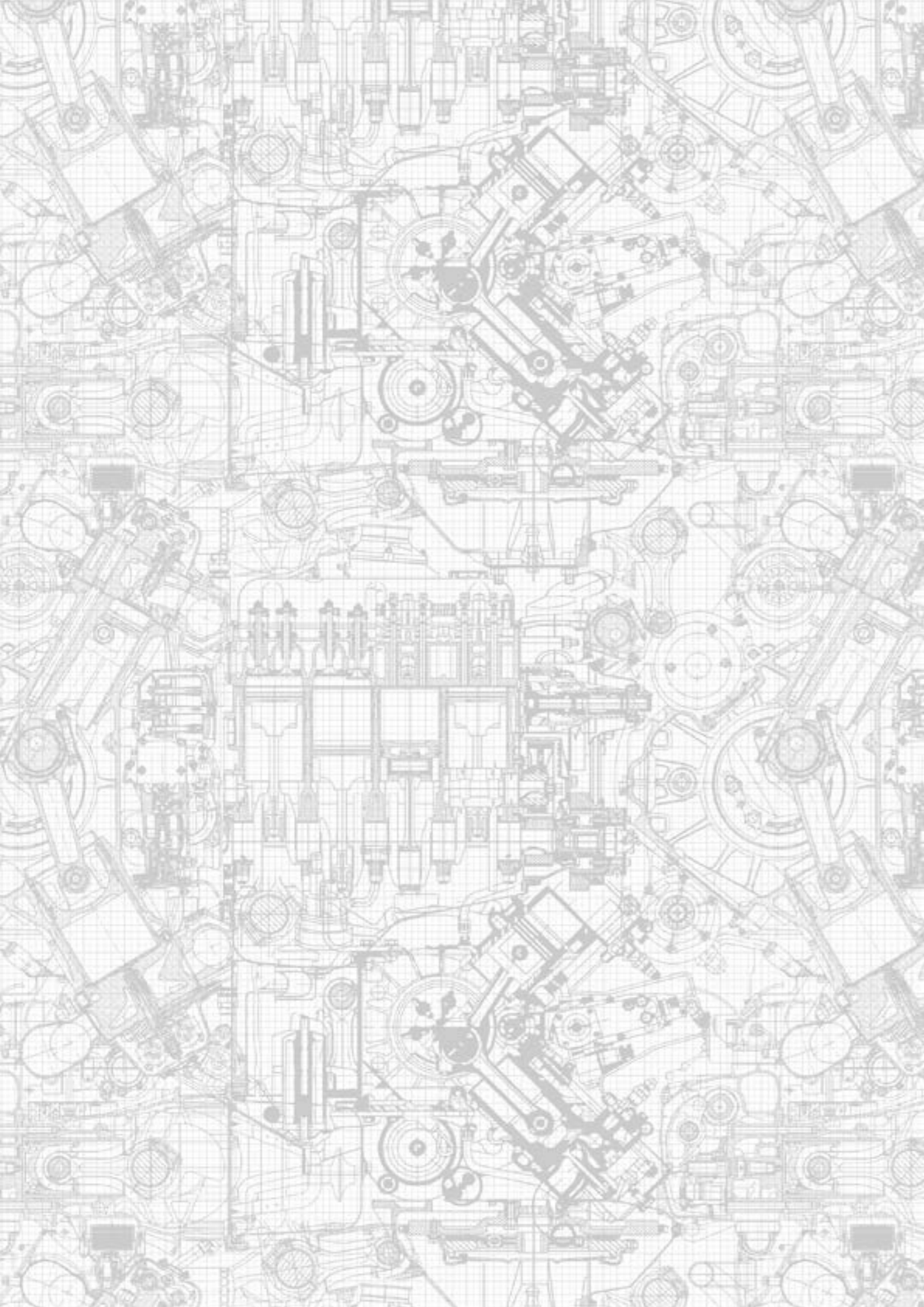

**DIESEL**



## Injector tester DSRX

007935105950

The most affordable automatic Common Rail injector tester on the market. The proven, intuitive, user-friendly design, thanks to the use of state-of-the-art technology, allows a quick and precise check of the technical condition of the injector under test.

Fast and accurate testing of Diesel CRDi injectors, thanks to the reliable dynamic dose measurement system - XKM.

- injector testing time 6-12 min.
- CRi (all makes and types).
- Support for all EU6 technologies, such as VCC and NCC technology, iART, PCR55 and more....
- CRIN injectors for light vehicles
- CRDi medium power injectors
- Maximum pressure 2000 bar.

New operating program with new functions, including: a list of cross references for a given injector, a detailed description of the connection, the ability to create a handy database. The ability to configure the device in the cloud, giving you access to reports, the current status of tester use and many other features.



|                |              |  |                    |
|----------------|--------------|--|--------------------|
| <b>X-Pack1</b> | ----         | DS1rX-ih, BCN.B, DFI.01, DFI.02, SVI.01, CZI.01, BPI.01, BCI.01, HP90-M14/F12x15, HP-M12/F14x15, CZ-008541 | STANDARD EQUIPMENT |
| <b>X-Pack2</b> | 007935105220 | CZ-007359, RSP, CZ-007124, DG3P-A, DG2P-A, DGxS-C, DGxS-A, DGxS-B) x1                                      | OPTION             |

## Injector tester CRU2RX

007935104440

High-tech, compact Common Rail injector tester. Professionals looking for advanced technology and broad application possibilities will particularly appreciate the device's capabilities. The device is equipped with 2 parallel XKM measurement systems. With the CRU2RX series, it is possible to generate new codes for Bosch (IMA, ISA), Delphi (C2i, C3i, C4i), Denso (QR Code), CAT, John Deere, Siemens/VDO (IIC, IIC.2) injectors - for VDO-authorized service centres only. In addition, it is possible to carry out a regeneration procedure for the piezo element in Bosch, Denso, and Siemens/VDO injectors. Extensive database for all types of electromagnetic and piezoelectric injectors: Bosch, Delphi, Denso, Siemens/VDO/Continental. Free automatic software updates via Wi-Fi.

- Injector testing time 6-12 min.
- CRi (all makes and types).
- Assigning new codes for all injector manufacturers
- Encoding after the purchase of a lifetime licence, or one-off via tokens
- Support for all EU6 technologies, such as VCC and NCC technology, iART, PCR55 and more....
- CRIN injectors for light and medium vehicles
- CRDi medium power injectors
- Maximum pressure 2800 bar.



|                   |              |  |                    |
|-------------------|--------------|--|--------------------|
| <b>X-Pack1</b>    | ----         | CRU2rX-ih, BCN.B, DFI.01, DFI.02, SVI.01, CZI.01, BPI.01, BCI.01, HP90-M14/F12x15, HP-M12/F14x15, CZ-008541, CZ-007356 | STANDARD EQUIPMENT |
| <b>X-Pack2</b>    | 007935105120 | Coding set: BC.01, DLC.03, DNC.04.v2, RSP, 007121  | OPTION             |
| <b>X-Pack_VDO</b> | 007935105130 | Set for VDO authorisation: VDO: - VC.05, VDO.AUTH, CZ-007359, RSP, 007121  | OPTION             |

## Injector tester ITB1RX / ITB4RX

ITB1RX air 007935104420  
ITB1RX water 007935104430  
ITB4RX air 007935104400  
ITB4RX water 007935104410

The latest device for testing Common Rail injectors on the market. Professionals looking for advanced technology and broad application possibilities will particularly appreciate the device's capabilities. The ITB1RX / ITB4RX test stand is a completely self-contained, free-standing, power-driven unit suitable for pressures up to 2800 bar. The unit can handle all injection systems, including Heavy Duty injectors. The ITB1RX / ITB4RX test benches are available with an air or water (mains connection required) cooling system.

With the ITB1RX / ITB4RX series, it is possible to generate new codes for Bosch (IMA, ISA), Delphi (C2i, C3i, C4i), Denso (QR Code), CAT, John Deere, Siemens/VDO (IIC) injectors - for VDO-authorized service centres only. In addition, it is possible to carry out a regeneration procedure for the piezo element in Bosch, Denso, and Siemens/VDO injectors. Extensive database for all types of electromagnetic and piezoelectric injectors: Bosch, Delphi, Denso, Siemens/VDO/Continental. Free automatic software updates via Wi-Fi. For ease of use, a drawer for handy keys and adapters is fitted under the screen.

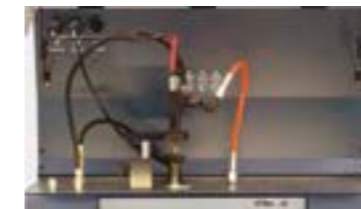

### ITB1RX accessory packages:

|                   |              |  |                    |
|-------------------|--------------|--|--------------------|
| <b>X-Pack1</b>    | ----         | CZ-007356, SVI.01, BCI.01, CZI.01, BCN.B, DFI.01, DFI.02, BPI.01, DEU.01, DGXS-A, DGXS-B, DG2P-A, DG3P-A | STANDARD EQUIPMENT |
| <b>X-Pack2</b>    | 007935105050 | Coding set: BC.01, DLC.03, DNC.04.v2, RSP, 007116  | OPTION             |
| <b>X-Pack3</b>    | 007935105060 | Advanced coding set: (BC.01, DLC.03, DNC.04.v2, CZ-007359, RSP, 007116, CRS.24, CZ-007114)x1, BCN.Bx1    | OPTION             |
| <b>X-Pack_VDO</b> | 007935105070 | Set for VDO authorisation: VC.05, VDO.AUTH, CZ-007359, RSP, 007116                                       | OPTION             |



### Pakiety akcesoriów ITB4RX:

|                   |              |   |                    |
|-------------------|--------------|---|--------------------|
| <b>X-Pack1</b>    | ----         | ((AZO.B4Mx1), [(SVI.01, BCI.01, CZI.01, BCN.B, DFI.01, DFI.02, BPI.01, DEU.01, DGXS-A, DGXS-B, DG2P-A, DG3P-A, CZ-007356) x 4 | STANDARD EQUIPMENT |
| <b>X-Pack2</b>    | 007935104990 | Coding set: (BC.01, DLC.03, DNC.04.v2)x1, RSPx4, [(007110, 007111) x1   | OPTION             |
| <b>X-Pack3</b>    | 007935105000 | Advanced coding set: (BC.01, DLC.03, DNC.04.v2)x1, [(CZ-007359, RSP)x4], CRS.24x2, [(007110, 007111) x1                       | OPTION             |
| <b>X-Pack_VDO</b> | 007935105010 | Set for VDO authorisation: (VC.05, VDO.AUTH) x1, [(CZ-007359, RSP)x4], [(007110, 007111) x1]                                  | OPTION             |



## MTBRX / PTBRX injector and pump tester

MTBRX Air (MM: 007935104360)

MTBRX Water (MM: 007935104370)

PTBRX Air (MM: 007935104380)

PTBRX Water (MM: 007935104390)

Magneti Marelli MTBRX and PT-BRX test benches are modern and efficient tools for the precise measurement and testing of technologically advanced injectors and pumps (PTBRX - pumps only) used in common rail power systems. The current series of equipment also allows for testing high-pressure injectors and pumps used in GDI/TSI engine supply systems. Magneti Marelli is constantly developing its range of equipment for testing and repairing injection systems, and the currently offered, fourth generation of equipment - the "X" series, is among the most innovative solutions of its kind on the market. The MTBRX can diagnose coil and piezo injectors, as well as CRp pumps from Bosch, Delphi, Siemens-VDO and Denso, with the addition of a special Cambox, for all types of EUI/EUP injectors and GDI injectors and pumps. The database contains the latest EU5 and EU6 applications.



## ETBRX control and measurement module

007935105890

The most up-to-date electronic control and measurement module on the market, enabling the control and precise measurement of all injection systems used in modern diesel engines. Testing of CRDi injectors, CRp pumps, and EUI/EUP and HEUI pump injectors of all types and from all manufacturers.

Can be mounted on any conventional test table on the market. Very compact and modern design. Freely configurable: test 1 or 4 injectors, and/or CRp pump. Clear operating interface, fast and convenient installation.



- Test of all types of CR injectors and pumps: Bosch, Delphi, Denso, Siemens/VDO and others, with reference to the test results in the database.
- Dynamic electronic measurement of fuel mass for both injector and pump testing - high-flow system for pumps, providing exceptional accuracy and unprecedented measurement speed (up to 4 minutes!)
- Ability to work with Cambox (007935101820), and test HEUI injectors (optional)
- Pressure control up to 2800 bar
- Coding of Delphi (C2i/C3i/C4i), Bosch (IMA/ISA), Denso (QR code) and other injectors
- Fully automatic operation



| MM code      | ETBRX               | ETBRX TEST MODULE FOR INJECTORS AND PUMPS - 1 SLOT, PRICE INCLUDES 1 SOFTWARE [CRDi, CRp, EUI/EUP, HEUI, EFI, GDI, GDP] |
|--------------|---------------------|---|
|              |                     | <b>SOFTWARE</b>   |
| 007935105810 | CRDi                | CRDi TESTING  |
| 007935105820 | CRp                 | CRP TESTING   |
| 007935105830 | Eui/Eup             | EUI/EUP TESTING EUI/EUP   |
| 007935105840 | HEUI                | HEUI HEUI TESTING   |
| 007935105850 | Gdi/GDp             | GDI/GDP EFI/GDI/GDP TESTING   |
| 007935105860 | 4 slots             | NJECTOR TESTING ON 4 SLOTS  |
|              |                     | <b>INSTRUMENTATION/DOSE MEASUREMENT (ELECTRONIC, MASS)</b>  |
| 007935105900 | 1 slot measurement  | INJECTOR MEASUREMENT - 1 SLOT   |
| 007935105910 | 4 slots test        | INJECTOR TESTING ON 4 SLOTS (4 SLOTS REQUIRED)  |
| 007935105920 | 4 slots measurement | INJECTOR MEASUREMENT - 4 SLOTS (4 SLOTS TEST REQUIRED)  |
| 007935105930 | Upgr 4 slots test   | UPGRADE FOR TESTING INJECTORS ON 4 SLOTS (1 SLOT MEASUREMENT REQUIRED)  |
| 007935105940 | CRp measurement     | PUMP MEASUREMENT (1 SLOT) INCLUDES AN EXTERNAL COOLING MODULE. (1 /4 SLOT MEASUREMENT REQUIRED)                         |



BCR.4 (MM: 007935106010) - Injector testing holder

Holder for 4 injectors with built-in Common-Rail with pressure control (RDS sensor and DRV valve), high-pressure hoses for injector connection and cover. Ready to be mounted on any conventional test bench. It allows the convenient installation and testing of up to 4 injectors using the ETBRX module.

## Accessories for injector and pump testers

We have a wide range of accessories and attachments for testing the latest types of Common Rail and GDI injectors and pumps. In most cases, these products fit not only our equipment, but also all test benches on the market. Take a look at our extensive range of goods for professionals looking for advanced solutions.

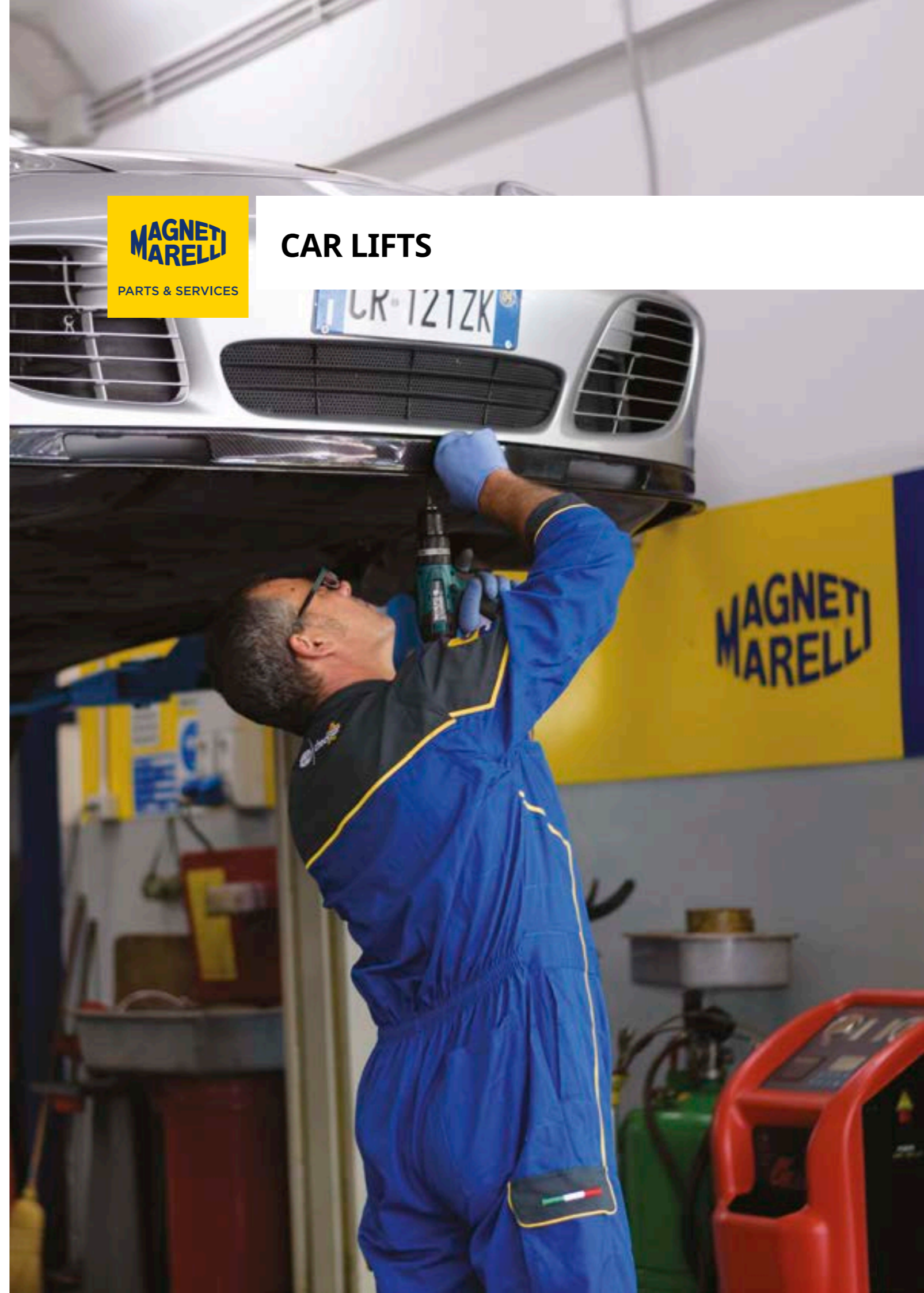

## CAR LIFTS

## MM Superlift 4000B/4000BS/220V

007935018165; 007935019990; 007935013715

### Floor Cover Plate Two Post Vehicle Lift



#### TECHNICAL DATA

| MODEL                               | MM Superlift 4000B     |
|-------------------------------------|------------------------|
| Capacity                            | 4.0 Ton                |
| Lifting height                      | 1930 mm (76")          |
| Min height                          | 90 mm (3½")            |
| Max car width                       | 2500 mm (100")         |
| Power supply                        | 220V 3PH 50/60Hz 2.2KW |
| Quantity of oil                     | 10 l                   |
| Foundation depth w/o floor covering | 300 mm                 |
| Concrete strength                   | B25                    |
| Fuse protection                     | 3C16 A                 |
| Size Of the concrete block          | 1,5 m x 4 m x 0,3 m    |
| Full rise time                      | 50s                    |
| Full rise                           | 1930 mm                |
| Height                              | 2824 mm                |
| Width                               | 3365 mm                |
| Inside columns                      | 2780 mm                |



#### OPTIONAL

NEW - 007935013715  
MM Superlift 4000B, 230V - lift  
2-column with connection on the floor,  
load capacity 4000 kg.

#### DIMENSIONS

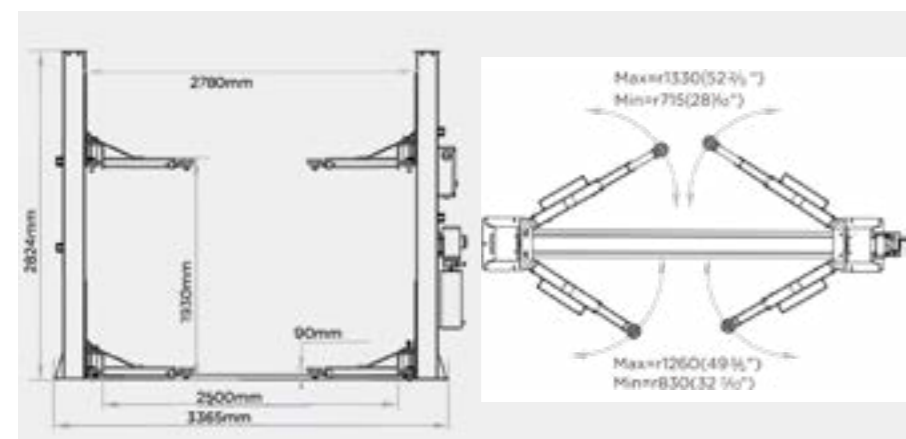

It is possible to order the lift in a version with a special reinforcement of the floor frame.  
007935019990 MM Superlift 4000BS

The version with an reinforced frame is only available upon special order!

The lift should be fixed on a smooth and solid concrete ground with its strength more than 210 kg/cm<sup>2</sup>, tolerance of fatness less than 5mm and minimum thickness of 300mm. In addition, newly built concrete ground must undergo more than 28 days' cure and reinforcement.

## MM Superlift 5000B

007935013690

### 2 post lift with floor cover plate, load capacity 5000kg.

### Long lifting arms.



#### TECHNICAL DATA

| MODEL                               | MM Superlift 5000B                        |
|-------------------------------------|---|
| Machine weight                      | 1000kg                                    |
| Lifting capacity                    | 5000kg                                    |
| Machine lift height                 | 1910mm                                    |
| Platform initial height             | 110mm                                     |
| Machine height                      | 2850mm                                    |
| Machine width                       | 3620mm                                    |
| Machine lifting time                | ≤45s                                      |
| Machine descent time                | About 45s                                 |
| Standard power supply               | 3/N/PE-380V, 50Hz,16A                     |
| Whole machine power                 | 3kW                                       |
| Hydraulic oil                       | 12L corresponds to wearable hydraulic oil |
| Working temperature                 | 5-40°                                     |
| Working humidity                    | 30-95%                                    |
| Noisy                               | < 70db                                    |
| Storage temperature                 | -25°-55°                                  |
| Foundation depth w/o floor covering | 300mm                                     |
| Concrete strength                   | B25                                       |
| Fuse protection                     | 3C16 A                                    |
| Size of the concrete block          | 1,5m x 4m x 0,3m                          |



#### DIMENSIONS

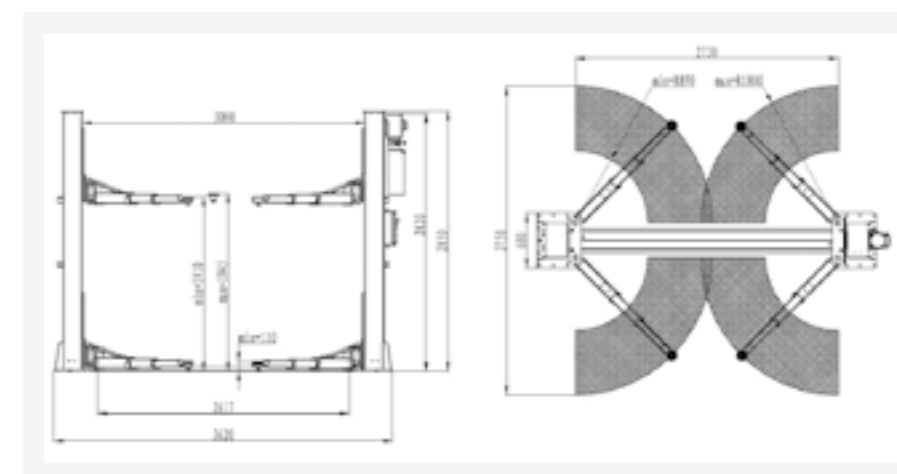

The lift should be fixed on a smooth and solid concrete ground with its strength more than 210 kg/cm<sup>2</sup>, tolerance of fatness less than 5mm and minimum thickness of 300mm. In addition, newly built concrete ground must undergo more than 28 days' cure and reinforcement.

## MM Superlift 4000UC/220V

007935018175; 007935013720

### Arch Type Clear Floor Two Post Vehicle Lift



#### TECHNICAL DATA

| MODEL                               | MM Superlift 4000UC                                       |
|-------------------------------------|---|
| Capacity                            | 4.0 Ton   |
| Lifting height                      | 1910 mm   |
| Min height                          | 110 mm  |
| Max car width                       | 2616 mm   |
| Power supply                        | 220V IPH 50/60 Hz 2.2 KW 230/400 V<br>3PH 50/60 Hz 2.2 kW |
| Machine weight                      | 670 kg  |
| Lifting capacity                    | 4000 kg   |
| Machine lift height                 | 1910 mm   |
| Platform initial height             | 110 mm  |
| Machine height                      | 3750 mm   |
| Machine width                       | 3420 mm   |
| Machine lifting time                | ≤45 s   |
| Machine descent time                | about 45s   |
| Standard power supply               | 3/N/PE-400V, 50Hz,10A                                     |
| Whole machine power                 | 2.2 kW  |
| Hydraulic oil                       | 8 L corresponds to wearable hydraulic oil                 |
| Working temperature                 | 5-40°C  |
| Working humidity                    | 30-95%  |
| Noisy                               | < 70db  |
| Storage temperature                 | -25°C-55°C  |
| Foundation depth w/o floor covering | 300 mm  |
| Concrete strength                   | B25   |
| Fuse protection                     | 3C16 A  |
| Size of the concrete block          | 1,5m x 4 m x 0,3 m  |



2 steps column design

#### DIMENSIONS

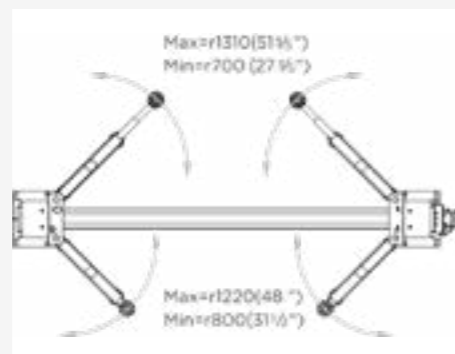
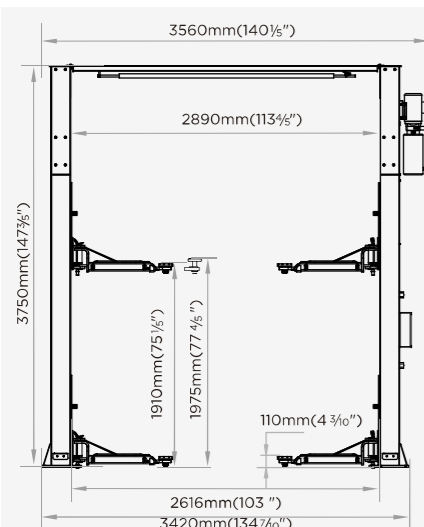

The lift should be fixed on a smooth and solid concrete ground with its strength more than 210 kg/cm<sup>2</sup>, tolerance of fatness less than 5mm and minimum thickness of 300mm. In addition, newly built concrete ground must undergo more than 28 days' cure and reinforcement.

## MM Superlift 6000UC

007935013685

MM Superlift 6000 UC - arch type clear floor 2 post lift, load capacity 6000kg. Height 5 m. Exworks-assembly cost must be verified with local installation team.



#### TECHNICAL DATA

| MODEL                               | MM Superlift 6000UC                       |
|-------------------------------------|---|
| Machine weight                      | 1400kg                                    |
| Lifting capacity                    | 6000kg                                    |
| Machine lift height                 | 1910mm                                    |
| Platform initial height             | 110mm                                     |
| Machine height                      | 5000mm                                    |
| Machine width                       | 3800mm                                    |
| Machine lifting time                | ≤55s                                      |
| Machine descent time                | About 55s                                 |
| Standard power supply               | 3/N/PE-380V, 50Hz,16A                     |
| Whole machine power                 | 3kW                                       |
| Hydraulic oil                       | 12L corresponds to wearable hydraulic oil |
| Working temperature                 | 5-40°                                     |
| Working humidity                    | 30-95%                                    |
| Noisy                               | < 70db                                    |
| Storage temperature                 | -25°-55°                                  |
| Foundation depth w/o floor covering | 300mm                                     |
| Concrete strength                   | B25                                       |
| Fuse protection                     | 3C16 A                                    |
| Size of the concrete block          | 1,5m x 4m x 0,3m                          |

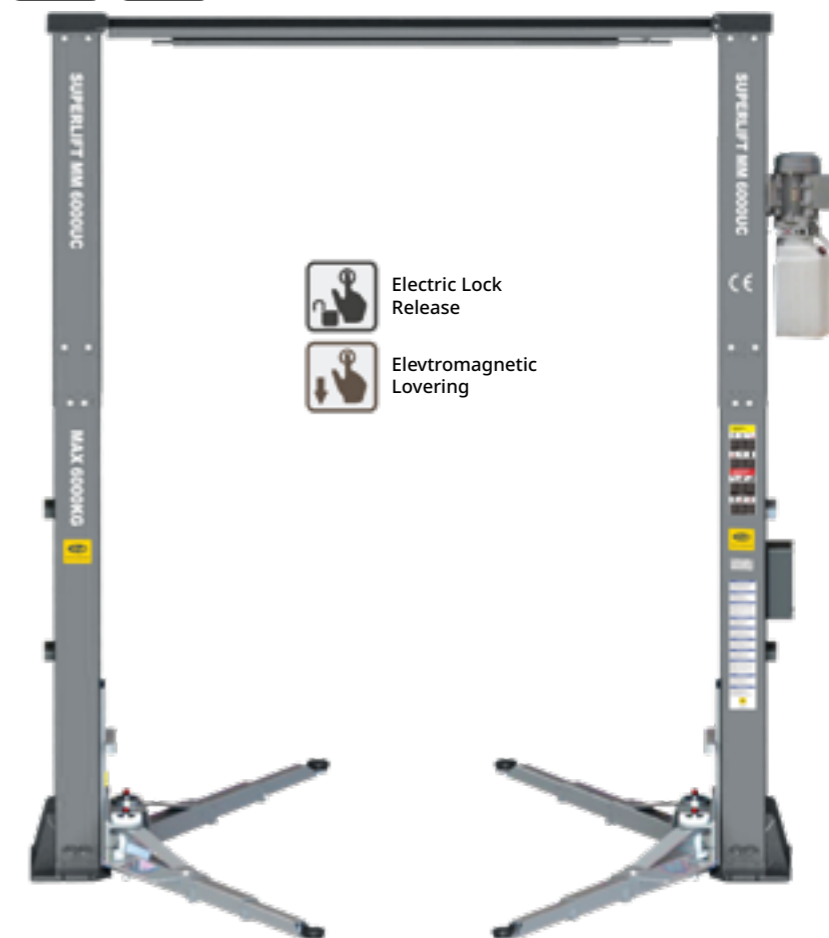

#### DIMENSIONS

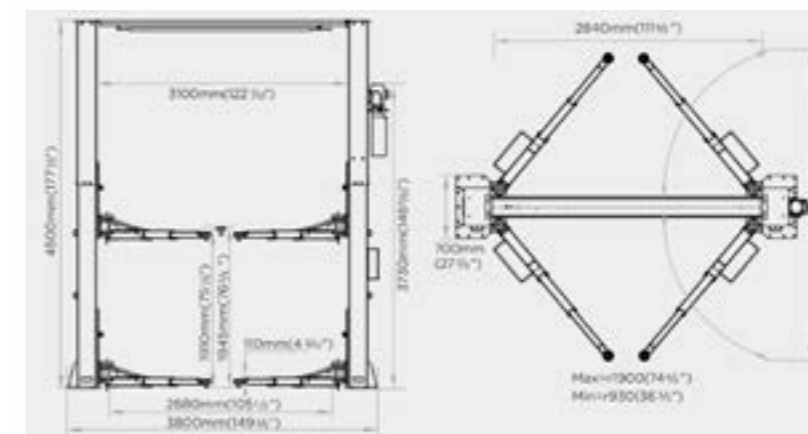

The lift should be fixed on a smooth and solid concrete ground with its strength more than 210 kg/cm<sup>2</sup>, tolerance of fatness less than 5mm and minimum thickness of 300mm. In addition, newly built concrete ground must undergo more than 28 days' cure and reinforcement.

# Mobile low lifting pantograph lift MMUH45M

007935011090

Superior quality: Precision manufacturing using laser cutting and robotic welding  
Sustainable technology: Robust and reliable hydraulic drive, almost maintenance-free  
Lifting power: Sturdy, high-strength construction provides high lifting power  
Maximum security: Hydraulic double lowering lock system; emergency lowering system in the event of a power failure;  
safe lowering with warning signal  
Modern design: Powder-coated lift in an attractive anthracite colour



## TECHNICAL DATA

|                           |                  |
|---------------------------|------------------|
| Model                     | MMUH45M          |
| Drive                     | Electrohydraulic |
| Lifting capacity          | 4500 kg          |
| Lifting height            | 620 mm           |
| Initial platform height   | 100 mm           |
| Platform length           | 1500 mm          |
| Platform width            | 580 mm           |
| Lifting time              | ≤20 s            |
| Lowering time             | ≤20 s            |
| Length of the entire lift | 2080 mm          |
| Width of the entire lift  | 1960 mm          |
| Power supply              | 220V, 50Hz, 10A  |
| Engine output             | 2.2 kW           |
| Hydraulic oil             | 6 l              |
| Operating temperature     | 5-40°C           |
| Storage temperature       | -25-55°C         |
| Noise                     | < 70db           |

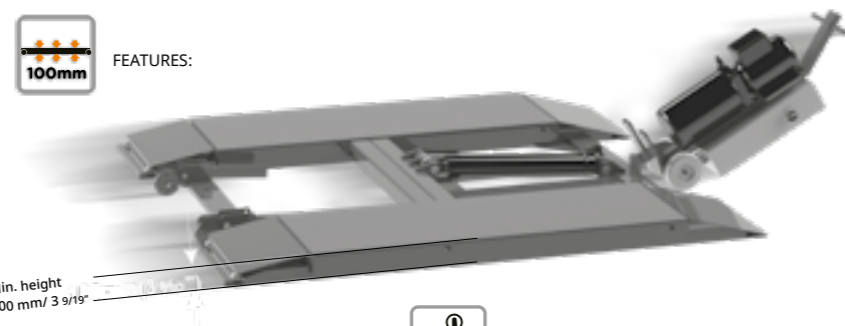
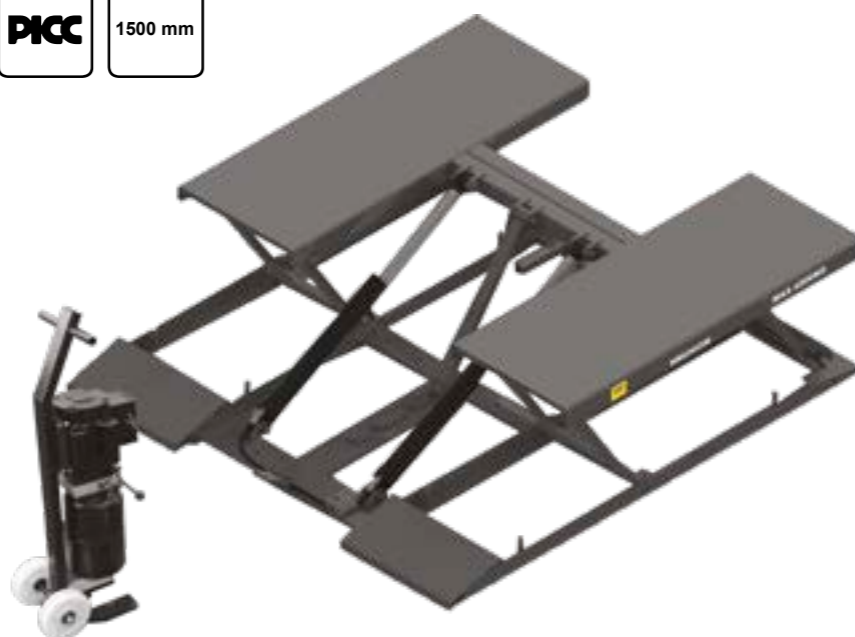

## DIMENSIONS

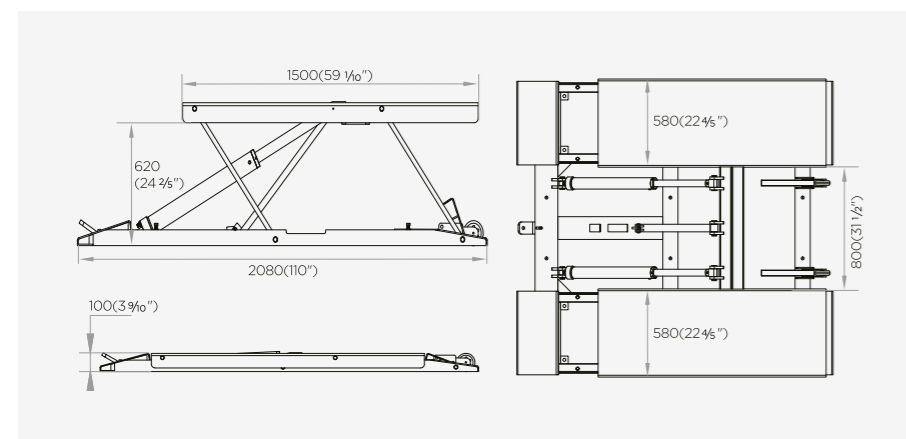

- Electromagnetic lowering
- Automatic unlocking
- Installation on a flat floor

- Requirements:**
- Class B25 concrete, drying period at least 15 days
  - Clean base course, concrete thickness >150 mm, level tolerance over entire length <10 mm
  - Connection of the wheelhouse to power supply (400 V)

# Mobile lift low Scissorlift lifting MMUZ30LM

007935011080

Superior quality: Precision manufacturing using laser cutting and robotic welding  
Sustainable technology: Robust and reliable hydraulic drive, almost maintenance-free  
Lifting power: Mechanical lever system for full power lifting  
Maximum security: Hydraulic double lowering lock system;  
emergency lowering system in the event of a power failure; safe lowering with warning signal  
Modern design: Powder-coated lift in an attractive anthracite colour



## TECHNICAL DATA

|                           |   |
|---------------------------|---|
| Model                     | MOBILE LIFT LOW Scissorlift LIFTING MMUZ30LM 007935011080 |
| Drive                     | Electrohydraulic  |
| Lifting capacity          | 3000 kg   |
| Lifting height            | 1010 mm   |
| Initial platform height   | 105 mm  |
| Platform length           | 1480 mm   |
| Platform width            | 480 mm  |
| Lifting time              | ≤35 s   |
| Lowering time             | ≤35 s   |
| Length of the entire lift | 2030 mm   |
| Width of the entire lift  | 1810 mm   |
| Power supply              | 220V, 50Hz, 10A   |
| Engine output             | 2.2 kW  |
| Hydraulic oil             | 6 l   |
| Ambient temperature       | 5-40°C  |
| Ambient humidity          | 30-95%  |
| Noise                     | < 70db  |
| Storage temperature       | -25°C-55°C  |



## DIMENSIONS

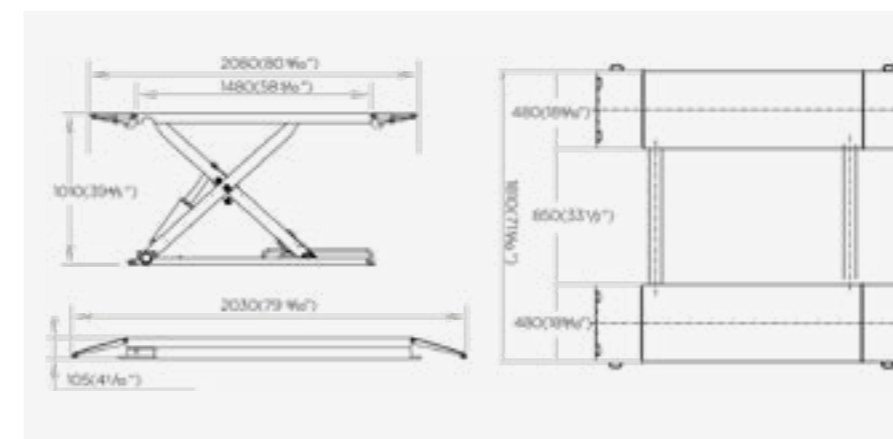

- Electromagnetic lowering
- Automatic unlocking
- Installation on a flat floor

- Requirements:**
- Class B25 concrete, drying period at least 15 days
  - Clean base course, concrete thickness >150 mm, level tolerance over entire length <10 mm
  - Connection of the wheelhouse to power supply (400 V)

## Low lifting scissor lift MMUZ30Y

007935011075

Superior quality: Precision manufacturing using laser cutting and robotic welding  
Sustainable technology: Robust and reliable hydraulic drive, almost maintenance-free  
Lifting power: Sturdy, high-strength construction provides high lifting power  
Maximum security: Hydraulic double lowering lock system;  
emergency lowering system in the event of a power failure; safe lowering with warning signal  
Modern design: Powder-coated lift in an attractive anthracite colour



### TECHNICAL DATA

| Model                      | LOW LIFTING SCISSOR LIFT<br>MMUZ30Y 007935011075 |
|----------------------------|--|
| Drive                      | Electrohydraulic                                 |
| Lifting capacity           | 3000 kg  |
| Lifting height             | 960 mm   |
| Initial platform height    | 105 mm   |
| Platform length            | 1450-2050mm                                      |
| Platform width             | 480 mm   |
| Lifting time               | ≤50 s  |
| Lowering time              | ≤60 s  |
| Length of the entire lift  | 2040 mm  |
| Width of the entire lift   | 1760 mm  |
| Power supply               | 3/N/PE-380V, 50Hz,10A                            |
| Engine output              | 2.2 kW   |
| Hydraulic oil              | 15 l   |
| Ambient temperature 5-40°C | 5-40°C   |
| Ambient humidity           | 30-95%   |
| Noise                      | < 70db   |
| Storage temperature        | -25°C-55°C                                       |



Overrun protection to stabilise longer vehicles on the platform



Rubber pads

### DIMENSIONS

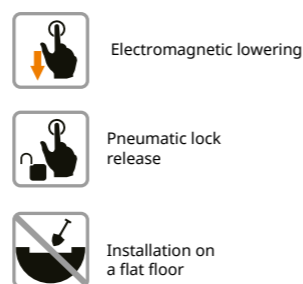
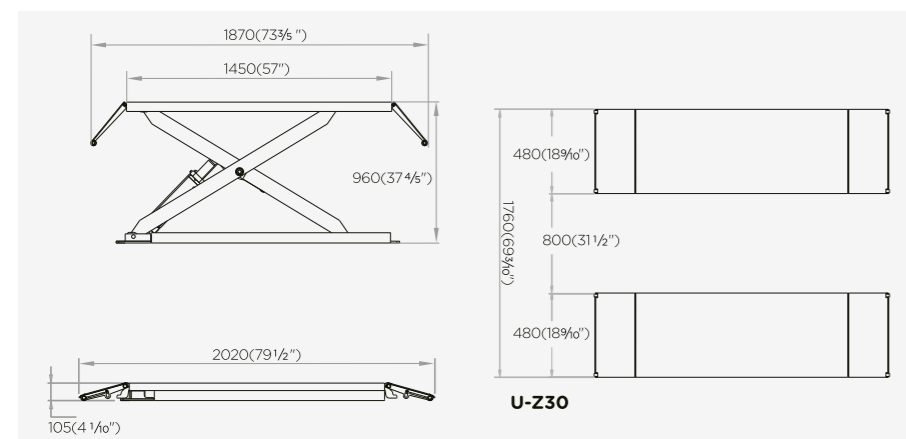

#### Requirements:

- Class B25 concrete, drying period at least 15 days
- Clean base course, concrete thickness >150 mm, level tolerance over entire length <10 mm
- Connection of the wheelhouse to power supply (400 V)
- Connection of the wheelhouse to the compressed air system (φ8 x 5mm)

## Sub-threshold scissor lift MMUB30Y

007935011085

Superior quality: Precision manufacturing using laser cutting and robotic welding  
Sustainable technology: Robust and reliable hydraulic drive, almost maintenance-free  
Lifting power: Sturdy, high-strength construction provides high lifting power  
Maximum security: Hydraulic double lowering lock system;  
emergency lowering system in the event of a power failure; safe lowering with warning signal  
Modern design: Powder-coated lift in an attractive anthracite colour



### TECHNICAL DATA

| Model                      | SCISSORS LIFT<br>SUBLIMINAL<br>MMUB30Y 007935011085 |
|----------------------------|---|
| Drive                      | Electrohydraulic                                    |
| Lifting capacity           | 3000 kg   |
| Lifting height             | 1850 mm   |
| Initial platform height    | 105 mm  |
| Platform length            | 1450-2050 mm  |
| Platform width             | 660 mm  |
| Lifting time               | ≤55 s   |
| Lowering time              | ≤55 s   |
| Length of the entire lift  | 2020 mm   |
| Width of the entire lift   | 2045 mm   |
| Power supply               | 3/N/PE-380V, 50Hz,10A                               |
| Engine output              | 2.2 kW  |
| Hydraulic oil              | 16 l  |
| Air pressure               | 6-8 bar   |
| Ambient temperature 5-40°C | 5-40°C  |
| Ambient humidity           | 30-95%  |



Overrun protection to stabilise longer vehicles on the platform

### DIMENSIONS

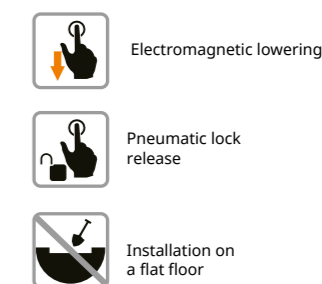
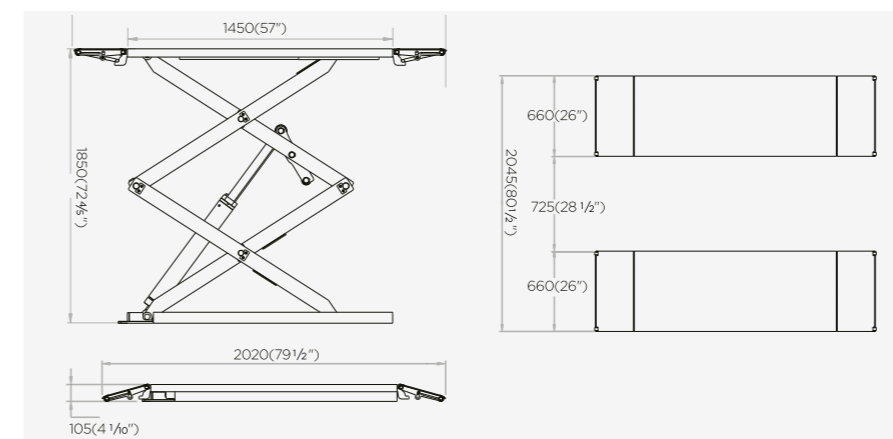

#### Requirements:

- Class B25 concrete, drying period at least 15 days
- Clean base course, concrete thickness >150 mm, level tolerance over entire length <10 mm
- Connection of the wheelhouse to power supply (400 V)
- Connection of the wheelhouse to the compressed air system (φ8 x 5mm)

# Scissor Lift MM Superlift MM Superlift 5000SC/5000SCX

007935018210; 007935011070

Superior quality: Precision manufacturing using laser cutting and robotic welding  
Sustainable technology: Robust and reliable hydraulic drive, almost maintenance-free  
Lifting power: Sturdy, high-strength construction provides high lifting power  
Maximum security: Hydraulic double lowering lock system;  
emergency lowering system in the event of a power failure; safe lowering with warning signal  
Modern design: Powder-coated lift in an attractive anthracite colour



## TECHNICAL DATA

| MODEL                                   | MM Superlift 5000SC/5000SCX |
|---|-----------------------------|
| Rated load capacity                     | 5500 kg                     |
| Drive                                   | Electrical hydraulic        |
| Main machine lift height                | 1850 mm                     |
| Platform initial height                 | 380 mm                      |
| Length of raids                         | 5000 mm                     |
| Platform width                          | 670 mm                      |
| Main machine lifting time               | ≤55 s                       |
| Main machine descent time               | ≤55 s                       |
| Whole machine length                    | 5500 mm                     |
| Whole machine width                     | 2140-2240 mm                |
| Lifting capacity of the under-axle lift | 3000 kg                     |
| Power supply                            | 3/N/PE-380V, 50Hz,10A       |
| Whole machine power                     | 2.2 kW                      |
| Hydraulic oil                           | 18 l                        |
| Air pressure                            | 6-8 bar                     |
| Working temperature                     | 5-40°C                      |
| Working humidity                        | 30-95%                      |
| Noise                                   | < 70 db                     |
| Storage temperature                     | -25°C-55°C                  |
| Concrete strength                       | B25                         |
| Fuse protection                         | 3C16 A                      |



## DIMENSIONS

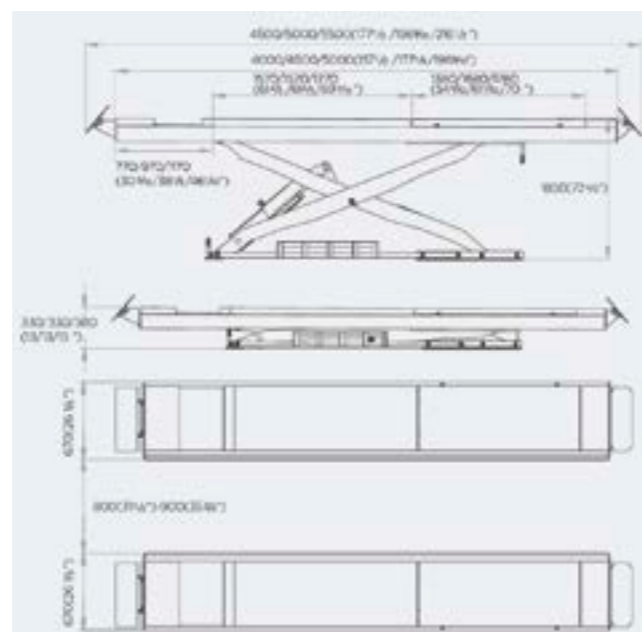

Pneumatic lock release



Electromagnetic lowering



For alignment

### Requirements

- Concrete type B25, the period of desiccation is 15 days
- Clean the basic layer, thickness of concrete ≥ 150 mm, the levelness of whole lengths ≤ 10 mm
- Perfect parallelism between holes.
- Connect to the power supply jack of control box (400V)
- Connect to the compressed air-entering pipe of control box (φ8×5mm)

# 4-column lift for geometry adjustment MM Superlift 5500QCLP

007935013980

Superior quality: Precision manufacturing using laser cutting and robotic welding  
Sustainable technology: Robust and reliable hydraulic drive, almost maintenance-free  
Lifting power: Sturdy, high-strength construction provides high lifting power  
Maximum security: Hydraulic double lowering lock system;  
emergency lowering system in the event of a power failure; safe lowering with warning signal  
Modern design: Powder-coated lift in an attractive anthracite colour



## TECHNICAL DATA

| Model                                   | 4-column lift for geometry adjustment<br>MM Superlift 5500QCLP<br>007935013980 |
|---|--|
| Drive                                   | Electrical hydraulic   |
| Rated load capacity                     | 5500 kg  |
| Main machine lift height                | 1750 mm  |
| Platform initial height                 | 250 mm   |
| Length of raids                         | 5490 mm  |
| Platform width                          | 530 mm   |
| Main machine lifting time               | ≤55 s  |
| Main machine descent time               | ≤55 s  |
| Whole machine length                    | 6490 mm  |
| Whole machine width                     | 3340 mm  |
| Lifting capacity of the under-axle lift | 3000 kg  |
| Power supply                            | 3/N/PE-380V, 50Hz,10A  |
| Whole machine power                     | 2.2 kW   |
| Hydraulic oil                           | 10 l   |
| Air pressure                            | 6-8 bar  |
| Working temperature                     | 5-40°C   |
| Working humidity                        | 30-95%   |
| Noise                                   | < 76 db  |
| Storage temperature                     | -25°C-55°C   |
| Concrete strength                       | C20  |
| Fuse protection                         | 3C16 A   |



Pneumatic lock release



Electromagnetic lowering



For alignment

### Requirements:

- Class B25 concrete, drying period at least 15 days
- Clean base course, concrete thickness > 150 mm, level tolerance over entire length < 10 mm
- Connection of the wheelhouse to power supply (400 V)
- Connection of the wheelhouse to the compressed air system (φ8 x 5mm)

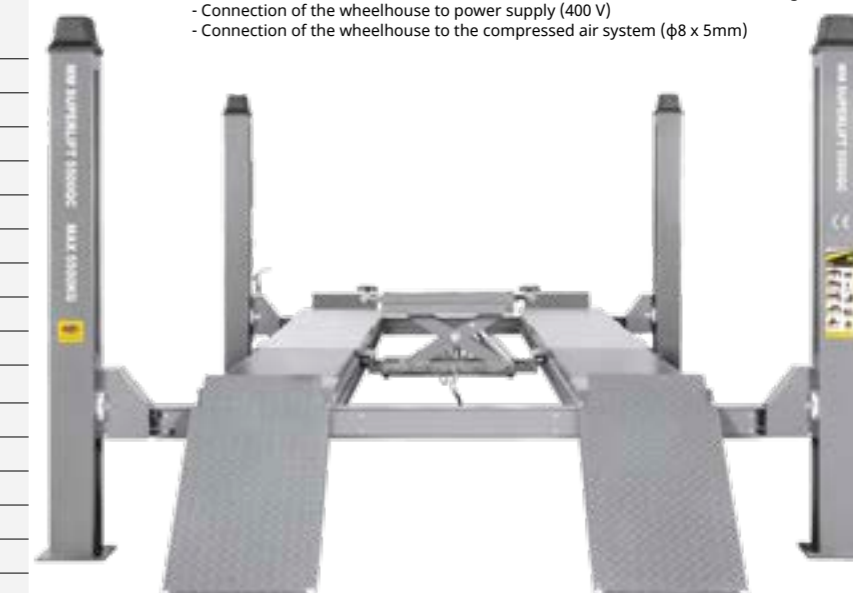

Pneumatic under-axle lift



Turntables and rear suspension release plates



Remote control

## DIMENSIONS

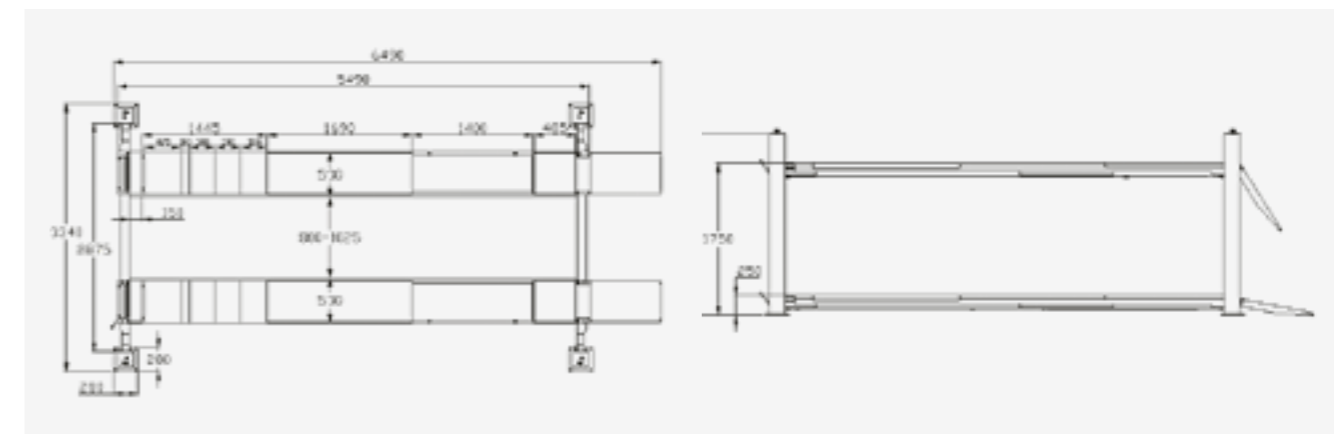

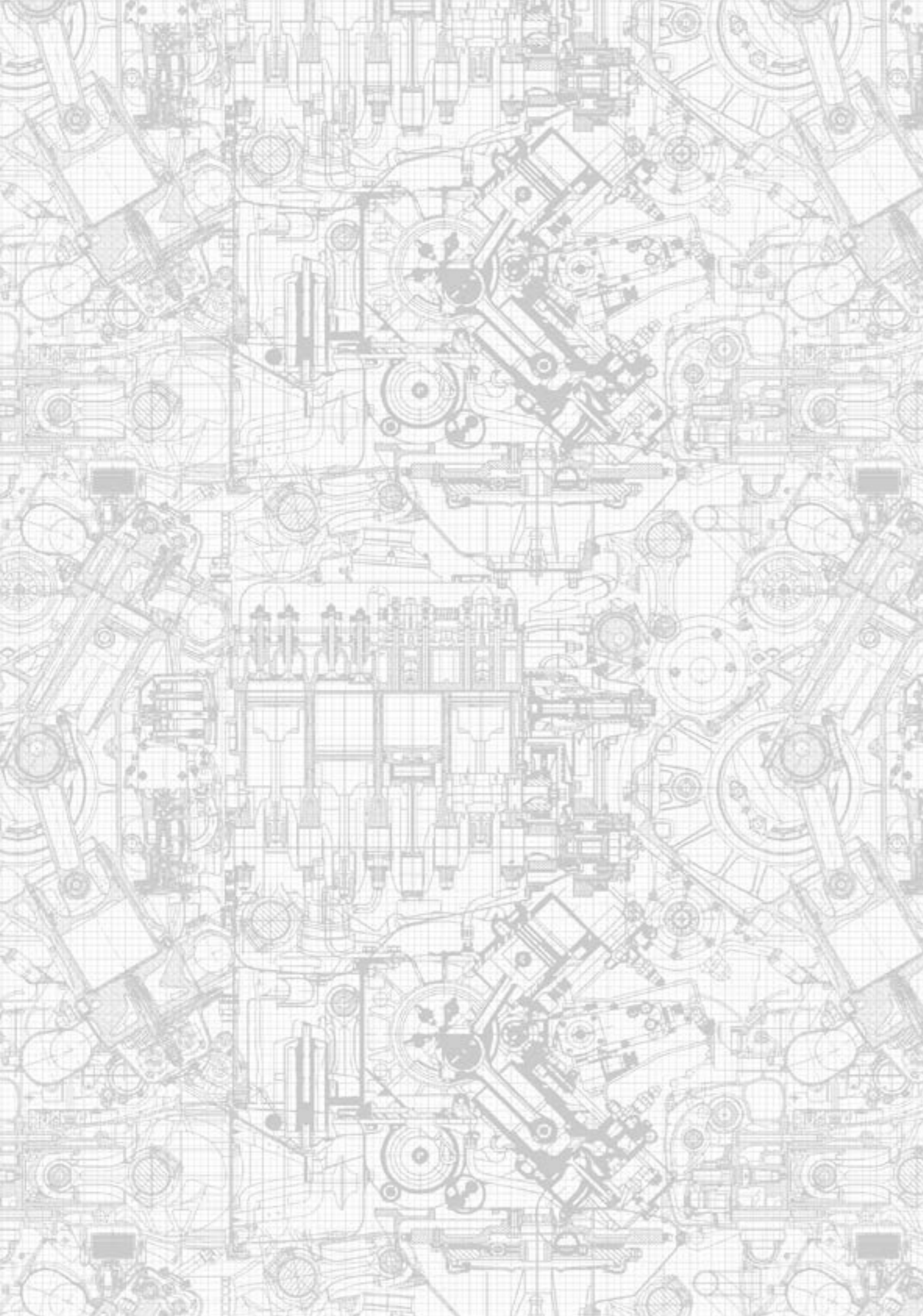

# WORKSHOP EQUIPMENT



## ATF EXTRA PRO 007935111060



### TECHNICAL DATA

- ▶ full automatic
- ▶ one-year license for the MM ATF INFOTEK database for free!
- ▶ precise measurement of the mass of new and old fluid
- ▶ automatic detection of flow direction
- ▶ variable displacement pump
- ▶ automatic gearbox flushing cycle
- ▶ illuminated sight glass for assessing fluid purity
- ▶ fluid temperature measurement
- ▶ Wi-Fi module (in ATF EXTRA PRO IOT)
- ▶ 5.5" color screen (in ATF EXTRA PRO IOT)
- ▶ drawer for handy tools (in ATF EXTRA PRO)
- ▶ thermal printer
- ▶ 12V DC power supply

### 007935110965

Database with information about chests automatic online - annual activation.



### ACCESSORIES

#### 007935110020

Spare filter for the ATF EXTRA PRO device

#### 007935111065

Board for hanging 79 adapters

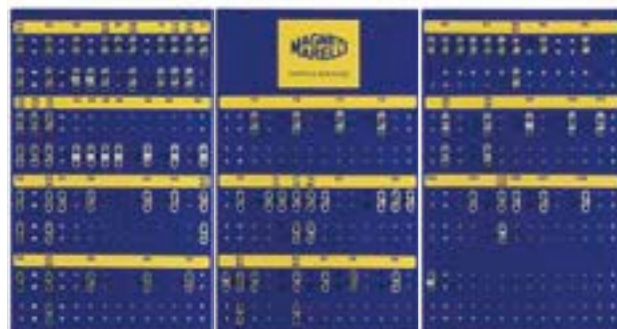

#### 007935110975

Set of 79 connectors for the ATF fluid replacement device



## MM TC-200 007935016745

The MM-TC200 device allows you to drain the gearbox from used oil, flush it with an appropriate detergent, and fill it with fresh oil up to the level recommended by the manufacturer. Unlike the previous version of the device, the MM-TC200 uses variable displacement pump, Parker quick couplers, new hoses inside the unit, and refreshed front panel. Thanks to the use of a 1-phase motor powered with 230V, the machine does not require complicated connections, which increases the flexibility of applications. The device operates in manual mode, which requires more intervention by the operator than in the case of a ATF Extra Pro. Adapters are not included in the unit and are available in sets or individually.



#### 007950025420

Flushing Fluid For Automatic Gerboxes  
1 L



#### 007950025430

Flushing Fluid For Automatic Gerboxes  
5 L



#### 007950026101

Fabric softener gearboxes  
12X400ml

#### 007950026100

Fabric softener gearboxes  
400ml



#### 007935013700 Manual pump for liquids with 20 adapters

Hand-held devices for filling gearboxes and differentials.



### TECHNICAL DATA

Maximum oil viscosity: SAE 140  
Tank capacity: 7.5l  
Drain pipe  
Connection hose: 2m  
Set of 20 connection adapters  
Operating temperature range: 0-60°C



## MM ATF INFOTEK 007935110965

- online database with information on automatic transmissions

## MM ATF INFOTEK 007935110970

online database with information on automatic transmissions

- license renewal for another year

The database contains several hundred vehicle models with detailed information on the types of gearboxes used in them. When using the ATF EXTRA PRO IOT, the parameters of the vehicle searched in the MM ATF INFOTEK database can be transferred via the internet to the device, so that it is automatically set up to handle the gearbox in question (amount of ATF fluid, flushing time, etc.). A clear service report will be generated on completion of the service.

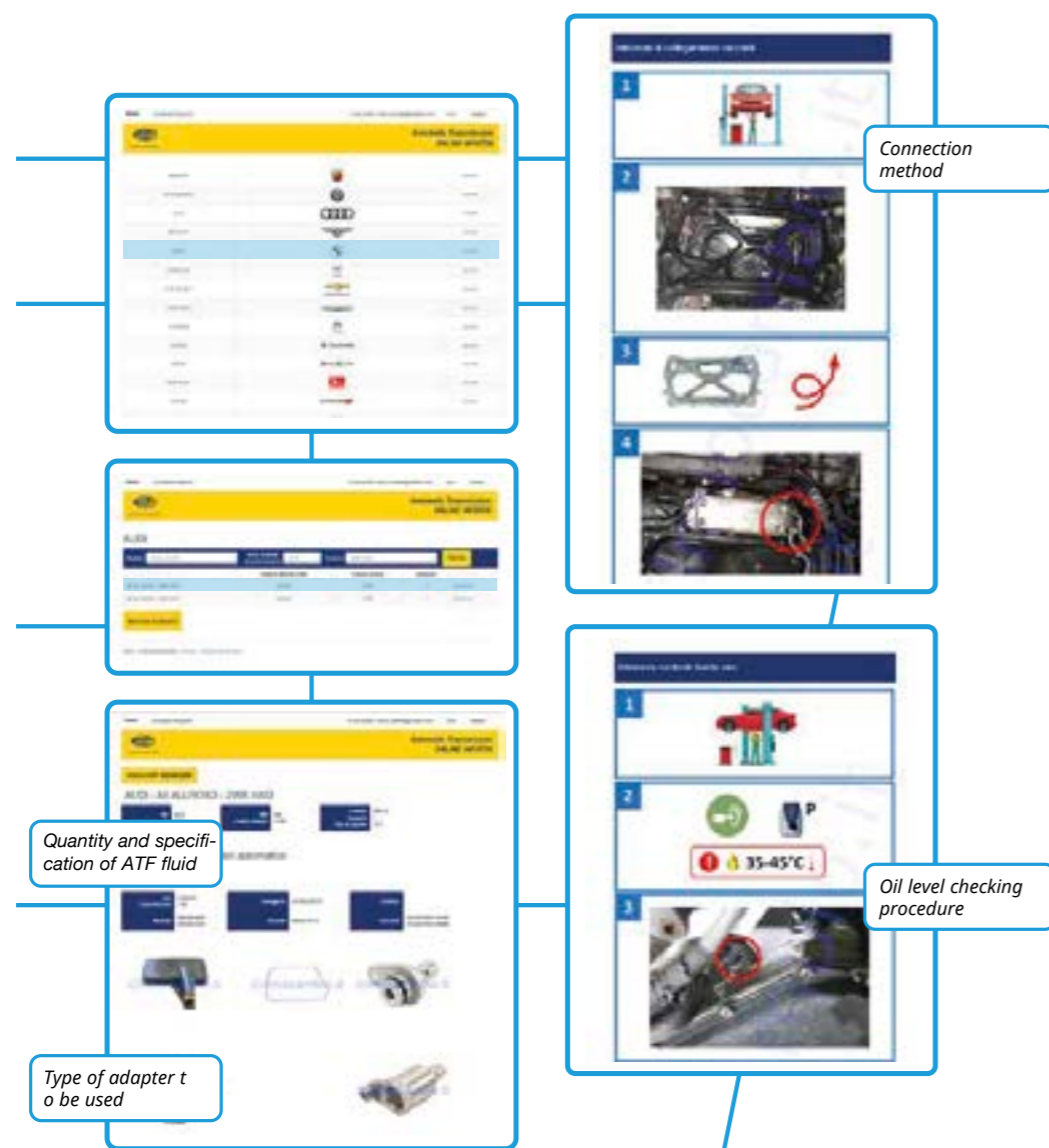

- ▶ an extensive vehicle database with 54 car brands, totalling more than 8,000 different versions.
- ▶ intuitive vehicle search, information in 23 languages
- ▶ information on the quantity and type of oil in a particular gearbox
- ▶ Identification of spare part numbers, such as oil sump and filter
- ▶ drawings and photos of actual gear components
- ▶ location of connectors to connect ATF fluid exchange device
- ▶ pictures and numbers of adapters fitting specific connectors
- ▶ description of procedure for checking gearbox oil level
- ▶ tightening torques for the various plugs (drain plug, filling plug, level check)
- ▶ data request function for crate models not currently in the database

## CONNECTORS, ADAPTERS



| ADAPTER    | MM CODE      | DESCRIPTION  |
|------------|--------------|--|
| number 001 | 007935110120 | Male adapter VOLVO (C30-C70-S40-S60-S70-S80-V40-V50-V70)   |
| number 003 | 007935110140 | Group adapter PSA - RENAULT  |
| number 004 | 007935110150 | Adapter VW DSG   |
| number 005 | 007935110160 | Female adapter GM - FIAT - FORD - JEEP - CHRYSLER - SAAB - MERCEDES  |
| number 006 | 007935110170 | Female adapter GM - FIAT - FORD - JEEP - CHRYSLER - SAAB - MERCEDES  |
| number 007 | 007935110180 | JEEP - MITSUBISHI - GM - SUZUKI - TOYOTA   |
| number 008 | 007935110190 | Male adapter AUDI  |
| number 009 | 007935110200 | Female adapter AUDI  |
| number 010 | 007935110210 | ALFA ROMEO 159   |
| number 014 | 007935110250 | Male adapter BMW - JAGUAR  |
| number 015 | 007935110260 | Female adapter BMW - JAGUAR  |
| number 016 | 007935110270 | Male adapter SAAB  |
| number 020 | 007935110310 | Male adapter BMW 1 (SERIE 7-Z3)  |
| number 021 | 007935110320 | Female adapter BMW 1 (SERIE 7-Z3)  |
| number 028 | 007935110390 | VW TRANSPORTER LT (2x1)  |
| number 029 | 007935110400 | Male adapter VOLVO (XC60-XC70-XC90)  |
| number 031 | 007935110420 | ALFA ROMEO 156 JTD   |
| number 032 | 007935110430 | Male adapter AUDI (100-A4-A5-A6-A8) VW (BEETLE-PASSAT-PHAETON-TIGUAN-TOUAREG)                                  |
| number 033 | 007935110440 | Female adapter AUDI (100-A4-A5-A6-A8) VW (BEETLE-PASSAT-PHAETON-TIGUAN-TOUAREG)                                |
| number 043 | 007935110530 | Cable 3/8 - ALFA ROMEO 156 1.6 and 166   |
| number 044 | 007935110600 | Connecting cable to 1/2" cable   |
| number 045 | 007935110540 | Cable 1/2 - BMW-CHEVROLET-HONDA-HYUNDAI-JAGUAR-JEEP-KIA-LAND ROVER-LEXUS-MITSUBISHI- OPEL- ROVER-SUZUKI-TOYOTA |
| number 046 | 007935110550 | Cable 3/4 - HONDA-HYUNDAI-KIA-LEXUS  |
| number 047 | 007935110560 | Adapter 90° - ALFA ROMEO 156 1.6e 166  |
| number 048 | 007935110570 | Adapter NISSAN - DAIHATSU - SUZUKI   |
| number 049 | 007935110580 | Adapter CAMBIO AISIN FIAT - LANCIA - FORD  |
| number 050 | 007935110610 | Adapter SC PSA 130mm   |
| number 053 | 007935110630 | Adapter AUDI A8 PORSCHE  |
| number 054 | 007935110640 | Male adapter BMW 6HP   |

| ADAPTER    | MM CODE      | DESCRIPTION  |
|------------|--------------|--|
| number 056 | 007935110650 | Male adapter BMW X5 X6                               |
| number 057 | 007935110660 | Male adapter BMW X5 X6                               |
| number 058 | 007935110670 | Adapter / flange NISSAN RENAULT MITSUBISHI           |
| number 061 | 007935130460 | Adapter BMW 6HP21 from 2006-                         |
| number 062 | 007935130450 | ADAPTER NISSAN RENAULT MITSUBISHI 6 SPEED from 2011- |
| number 063 | 007935130470 | Adapter 9HP - JEEP - DFromGE - FIAT from 2014-       |
| number 064 | 007935130480 | Adapter 9HP - RANGE ROVER from 2011-                 |
| number 065 | 007935130490 | Male adapter BMW 8HP-45 from 2011-                   |
| number 066 | 007935130500 | Male adapter BMW 8HP-45 from 2011-                   |
| number 068 | 007935110760 | Adapter CVT K41 TOYOTA from 2008-                    |
| number 069 | 007935110765 | Adapter from TG81 VOLVO - BMW/Mini/Saab from 2016    |
| number 070 | 007935110770 | Adapter from TF71 - 72 - PSA - BMW from 2015-        |
| number 071 | 007935110775 | Adapter from VOLVO                                   |
| number 072 | 007935110782 | Adapter 2 for TF71 - 72 - PSA - BMW                  |
| number 073 | 007935110783 | Adapter GA6F21AW - BMW - MINI                        |
| number 074 | 007935110785 | Adapter from Toyota Avensis K311                     |
| number 075 | 007935110790 | Adapter from Toyota Corolla                          |
| number 076 | 007935110805 | Adapter STELVIO (2 sztuki)                           |
| number 077 | 007935110810 | Male adapter TOYOTA-LEXUS small diameter             |
| number 078 | 007935110815 | Male adapter TOYOTA-LEXUS small diameter             |
| number 079 | 007935110820 | Male adapter TOYOTA-LEXUS large diameter             |
| number 080 | 007935110825 | Male adapter TOYOTA-LEXUS large diameter             |
| number 081 | 007935110830 | Adapter from NISSAN CVT                              |
| number 082 | 007935110835 | Adapter from JAGUAR LAND ROVER (3 PZ)(082)           |
| number 083 | 007935110840 | Adapter from VOLKSWAGEN TIGUAN (083)                 |
| number 084 | 007935110905 | Male adapter FORD (084)                              |
| number 085 | 007935110910 | Male adapter FORD (085)                              |
| number 086 | 007935110845 | Male adapter MERCEDES 7 MARCE (086)                  |
| number 087 | 007935110850 | Male adapter MERCEDES 7 MARCE (087)                  |
| number 088 | 007935110855 | Adapter from PIASTRA MAZDA 6 MARCE (088)             |
| number 089 | 007935110915 | Male adapter AUDI LANDROVER JAGUAR(089)              |
| number 090 | 007935110920 | Adapter from COMPOSTO FORD RANGER (090)              |
| number 091 | 007935110925 | Adapter from COMPOSTO IVECO (091)                    |
| number 092 | 007935110860 | Male adapter AUDI OBK (092)                          |
| number 093 | 007935110865 | Male adapter AUDI OBK (093)                          |
| number 094 | 007935110870 | Adapter from PSA 8 MARCE (SCAMB ALTO)(094)           |
| number 095 | 007935110875 | Adapter from PSA 8 MARCE (SCAMB BASSO)(095)          |
| number 096 | 007935110880 | Male adapter AUDI VW (096)                           |
| number 097 | 007935110885 | Male adapter AUDI VW (097)                           |
| number 098 | 007935110890 | Adapter from FORD TRANSIT (098)                      |
| number 099 | 007935110930 | Adapter from SINGOLO MERCEDES 7G DCT V2(099)         |
| number 100 | 007935110935 | Adapter from PIASTRA BMW MINI (100)                  |
| number 101 | 007935110940 | Male adapter BMW G (101)                             |
| number 102 | 007935110945 | Male adapter BMW G (102)                             |
| number 103 | 007935111070 | Adapter BMW MINI (103)                               |
| number 104 | 007935110990 | Male adapter VOLVO FORD LAND ROVER JAGUAR (104)      |
| number 105 | 007935110995 | Male adapter AUDI PORSCHE (105)                      |
| number 106 | 007935111000 | Male adapter SAAB MERCEDES JEEP (106)                |
| number 107 | 007935111075 | Adapter HONDA 9HP (107)                              |
| number 108 | 007935111005 | Single adapter 6 DCT 450/470 (108)                   |

## Tyre changers



**Tyre fitting machine MM-HC1224LL**

007935017775

**Tyre fitting machine MM-HC1224LL2V**  
- 2 table speeds

007935017875

**Tyre fitter MM-HC1224LLTI2V**  
- 2 table speeds + inflator

007935017885

**Characteristic:**

- ▶ Automatic handling of rims from 11" to 27"
- ▶ External spacing up to 25"
- ▶ Mechanical pin lock
- ▶ Standard operating lever with pneumatic cylinder
- ▶ Pneumatically swivelling working arm
- ▶ Set of alloy wheel covers included
- ▶ Support arm for low-profile tyres
- ▶ Two table speeds - model MM-HC1224LL2V and MM-HC1224LLTI2V
- ▶ Inflator in table jaws - model MM-HC1224LLTI2V
- ▶ Automatic tyre fitting/removal head - optional

**Technical data:**

- ▶ Dimensions of outer locking rim 10-25"
- ▶ Dimensions of inner locking rim 12-27"
- ▶ Max. wheel diameter 1143 mm (45")
- ▶ Max. wheel width 406 mm (16")
- ▶ Operating pressure 810 bar
- ▶ Power supply 110V (1ph)/ 220V (1ph)/ 380V (3ph)
- ▶ Optional motor power 0.75/0.55/1.1 kW
- ▶ Max. torque (rotary table) 1078 Nm
- ▶ Overall dimensions 1130x900x1030mm
- ▶ Noise level <75dB

Complete set: Auxiliary arm, tyre lever, covers (jaws, impactor, head, rim), tyre pressure, hose, inflation gun with electronic pressure gauge (on MM-HC1224LLTI2V a pedal-operated unit with pressure gauge for inflating the wheel), brush



**MMU290 Truck wheel fitter 14"-26"**

007935013755

**Characteristic:**

The MMU290 fitter has been specially designed for removing bus and truck tyres with rims from 14" to 26" in diameter and a maximum tyre diameter of 1600 mm. The strong wheel holder ensures stable and safe operation, and the efficient hydraulic drive allows for easy tire replacement.

**Technical data:**

- ▶ Hydraulic pump motor 1.5 kW
- ▶ Wheel rotation drive 2.2 kW
- ▶ Range of supported rims 14"-26"
- ▶ Max. wheel diameter 1600 mm
- ▶ Max. wheel width 780 mm
- ▶ Max. wheel weight 500 kg
- ▶ Operating noise <70 dB (A)



**Tyre changer**

**MM-TC1223V(2 SPEED)**

007935017240

**Tyre changer**

**MM-TC1223VIT**

**(2 SPEED,INFLATOR)**

007935017250

**Characteristic:**

- ▶ Automatic handling of rims from 11" to 26"
- ▶ External spacing up to 23"
- ▶ Mechanical pin lock
- ▶ Standard operating lever with pneumatic cylinder
- ▶ Two table operating speeds
- ▶ Pneumatically swivelling working arm
- ▶ Inflator with pressure gauge - Version MM-TC1223 2V IT
- ▶ Auxiliary arm for non-standard rims (optional)

**Technical data:**

- ▶ Dimensions of outer locking rim 12-23"
- ▶ Dimensions of inner locking rim 14-26"
- ▶ Max. wheel diameter 1143 mm (45")
- ▶ Max. wheel width 406 mm (16")
- ▶ Operating pressure 810 bar
- ▶ Power supply 110V (1ph)/ 220V (1ph)/ 380V (3ph)
- ▶ Optional motor power 0.75/ 0.55/ 1.1 kW
- ▶ Max. torque (rotary table) 1078 Nm
- ▶ Overall dimensions 1130x900x1050mm
- ▶ Noise level <75 dB
- ▶ Two table speeds
- ▶ Inflator

Complete set: Tyre lever, hose, inflation gun with pressure gauge (pedal-operated wheel inflation gauge module on MM-TC1223 2V IT), brush

## Wheel balancers



**Wheel balancers MM-HC1024FA**  
007935017275

**Characteristic:**

- ▶ 17" LCD monitor, intuitive and flexible user interface
- ▶ Various balancing programmes: static, dynamic,
- ▶ 9 wheel balancing modes
- ▶ Automatic measurement of wheel parameters, including rim width
- ▶ Intelligent auto-calibration and self-diagnosis function
- ▶ Holder for handy tools and mounting cones

**Technical data:**

- ▶ Wheel weight max: 65 kg
- ▶ Engine power: 200 W
- ▶ Power supply: 230 V/50 Hz
- ▶ Balancing precision: ±1 g
- ▶ Rotation speed: 200 rpm
- ▶ Cycle time: 8 s
- ▶ Rim diameter: 10" - 24"(256mm - 610mm)
- ▶ Rim width: 1,5" - 20"(40mm - 510mm)
- ▶ Noise level: <70 dB
- ▶ Net weight: 105 kg
- ▶ Dimensions: 960mmx760mmx1600mm

**Standard equipment:**

- ▶ Protective cover
- ▶ Centring cones
- ▶ Pliers
- ▶ Calliper
- ▶ Shaft
- ▶ Lock



**Wheel balancers MM-HC1024FA**  
007935017805

**Characteristic:**

- ▶ 17" LCD monitor, intuitive and flexible user interface
- ▶ Various balancing programmes: static, dynamic,
- ▶ 9 wheel balancing modes
- ▶ Automatic measurement of wheel parameters, including rim width
- ▶ Intelligent auto-calibration and self-diagnosis function
- ▶ Holder for handy tools and mounting cones

**Technical data:**

- ▶ Wheel weight max: 65 kg
- ▶ Engine power: 200 W
- ▶ Power supply: 230 V/50 Hz
- ▶ Balancing precision: ±1 g
- ▶ Rotation speed: 200 rpm
- ▶ Cycle time: 8 s
- ▶ Rim diameter: 10" - 24"(256mm - 610mm)
- ▶ Rim width: 1,5" - 20"(40mm - 510mm)
- ▶ Noise level: <70 dB
- ▶ Net weight: 105 kg
- ▶ Dimensions: 960mmx760mmx1600mm

**Standard equipment:**

- ▶ Protective cover
- ▶ Centring cones
- ▶ Pliers
- ▶ Calliper
- ▶ Shaft
- ▶ Lock
- ▶ Calibration weight

**MMU150 Truck wheel balancer**  
007935013760

**Characteristic:**

- ▶ Different balancing modes for punched and glued weights
- ▶ Smart self-calibration.
- ▶ Self-diagnosis of faults and safety functions].
- ▶ For steel and aluminium rims.
- ▶ Equipped with a pneumatic wheel lifting device.
- ▶ Equipped with a brake pedal for stable positioning and convenient weight acquisition

**Technical data:**

- ▶ Maximum wheel weight: 150 kg
- ▶ Engine power: 0.75 kW
- ▶ Power supply: AC 220 V /380 V 50 Hz
- ▶ Rotation speed: 200 rpm
- ▶ Cycle time: 8 s
- ▶ Rim diameter: 10 - 24 - (252 mm - 610 mm)
- ▶ Rim width: 1.5 - 20 - (40 mm - 510 mm)
- ▶ Noise: - 70 dB
- ▶ Net weight: 250 kg
- ▶ Dimensions: 1220 mm x 960 mm x 1210 mm (4.0 x 3.2 x 4.0 ft)



Help arm FOR MM  
TC1223  
**007935017270**



Set of adapters for  
ATV  
**007960009935**



Self-Centering Flange For  
Motorcycle Wheels, Rotation  
Via Application To Wheels  
From Outside. The Gtm2  
Must Be Completed With  
Garp.  
**007960001300**



Set of adapters for  
motorcross alloys  
**007960009930**



Centering Accessory For Vans And  
Off-Road Vehicles With Centre  
Hole Wheels. From Hole Ø 117  
To 173 Mm  
**007960001290**



Belzer Pliers  
**007960001350**



Accessory For Off-Road Wheels  
With Central Hole. From Hole Ø  
101 To 119 Mm  
**007960001280**



Universal flange for wheels  
without a central hole  
**007960009650**



Bead breaker shovel protection  
cover  
**007935017265**



Adapter for  
motorcycles  
for MM-WB1024  
**007935017290**



Plastic covers for jaws long  
(set 4 pcs)  
**007935017260**



Large centering cone  
for MM-WB1024  
**007935017285**



Plastic covers for jaws  
short (set 4 pcs)  
**007935017255**



Universal wheel flange  
MM-WB1024  
**007935017295**



D. 18 Shaft Set Complete With Cones,  
Bushings And Locking Ring Nut.  
For Very Heavy Motorcycle Wheels  
**007960001310**



# POWERGY 2500

## Pneumatic McPherson column charger, 2.5t pressure

007935063905

The scope of application of the pneumatic coil spring compressor covers all types of passenger cars, SUVs and delivery vehicles. To ensure maximum user safety, the machine is equipped with a system of active and passive protections: pneumatic cylinder, foot pedal, safety cage, shock absorber, protection against dropped objects and plinth.

### ACTIVE AND PASSIVE SYSTEM SECURITY:

- ▶ Complete protection is provided by the locking system made of highly resistant polycarbonate
- ▶ Synchronized opening of both doors one hand
- ▶ The user can work safely - no need to place hands on a spring during compression phases

- ▶ Spring diameter from Ø 78 mm to 185 mm.
- ▶ Bracket locking system: hydraulic shaft up to Ø 60 mm.
- ▶ Retaining coil spring clamp coil spring Ø 13.5-18 mm still when compressed.
- ▶ Wide range of compression stroke up to 330 mm

### VALVES SECURITY:

- ▶ 2 shut-off valves safety on the cylinder
- ▶ 1 safety valve control security
- ▶ 1 safety valve pneumatic system

### SPRING COMPRESSION SYSTEM:

- ▶ Dual position bracket plate in order to increase the range of dismantled shock absorbers (SUVs, delivery vehicles, etc.)
- ▶ Possibility to work on a coil spring right-handed
- ▶ Possibility to work on a coil spring left-handed
- ▶ The shock absorber can be locked into pieces hydraulic (bracket function)

### UPPER FREE CLAMPS:

- Adjustment angle: 0°, (+/-)15°
- Free-floating clamps allow better capture the spring, dynamically adjusting your position while different compression phases

### SHAFT SUPPORT:

- Height adjustable
- Adjustable within 180°

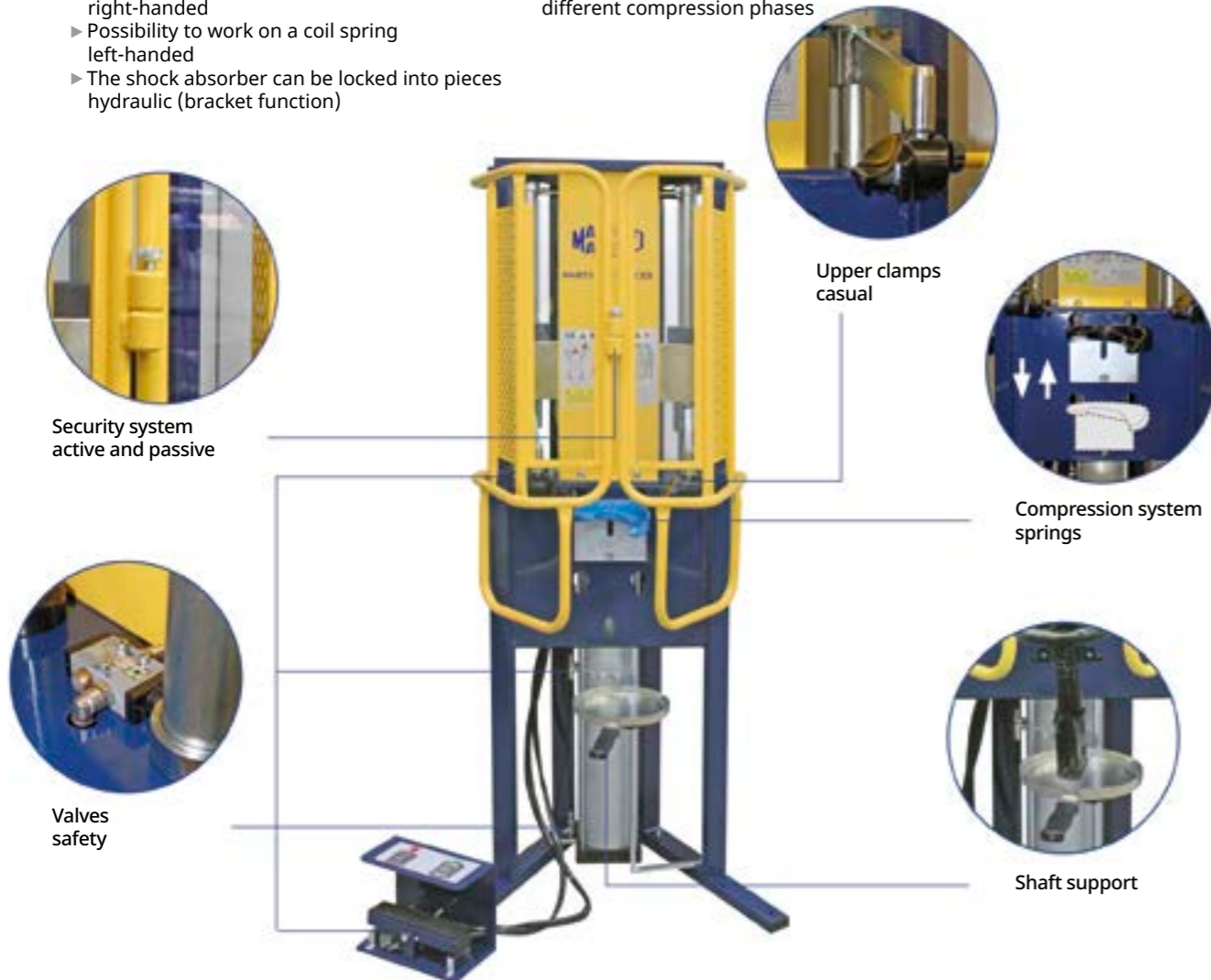

**ALUMINUM CYLINDER** - The cylinder is made of light alloy and fiberglass nylon resin, which prevents corrosion and oxidation of machine parts.

**UNIVERSAL USE** - Two upper arms with automatic leveling make it easier to work on springs conical, non-coaxial and banana-shaped springs.

## EQUIPMENT SUPPORTS AND VICE - optional accessories

| KOD          |  | TYPE  | APPLICATION  | TECHNICAL PROPERTIES  |
|--------------|--|---|--|---|
| 007935063790 |  | Small bracket (included)                        | The bracket allows the spring to be compressed for faster replacement and ensuring maximum user safety       | For springs Ø 78-130 mm   |
| 007935063800 |  | Medium bracket (included)                       |  | For springs Ø 105-185 mm  |
| 007935063920 |  | Medium left bracket (included)                  |  | For left springs Ø 105-187 mm   |
| 007935060310 |  | Vice (included)                                 | The vice allows you to mount the shock absorber mount on the guide leg and disassembly from the shin         | For shock absorbers Ø 40-60 mm  |
| 007935063915 |  | Swiveling jaws upper (included)                 | Self-adjusting serving system for better fastening springs during compression                                | Adjustment angle 0°, (+/-) 15°  |
| 007935063810 |  | Large bracket (option)                          |  | Application: from Ø 125 up to Ø 205 mm up to 2.5 tons                               |
| 007935063830 |  | Spring clamp screw (option)                     | It is used to immobilize the spring screw during initial compression and torsion restrictions by the bracket | For springs Ø 13.5-18 mm  |
| 007935063910 |  | Upper shock absorber column mounting (option)   | allows you to compress the column by the main mounting, recommended for springs with a small number of turns |   |
| 007935060650 |  | Blocking Vice For Honda, Toyota (Chosen Models) |  | application: rear BMW shock absorbers, Jeep Cherokee front, selected Asian vehicles |
| 007935063820 |  | Bracket for Mercedes-Benz (optional)            |  | application: Mercedes Benz: Class A, B, C, E  |

# POWERGY 1000

## Pneumatic McPherson column changer, 1t pressure

007935060300

The POWERGY 1000 device operates using compressed air from a compressor and is used to dismantle and install shock absorbers from a Mc Pherson strut. The equipment includes a universal vice for gripping the shock absorber base (007935060310). Other dedicated handles are optional. Thanks to them, disassembly of the shock absorber is quick and safe. Keeping the spring compressed significantly reduces replacement time. The device is particularly suitable for new types of misaligned and conical shock absorbers, thanks to a self-aligning beam that adjusts to any misalignment. The device is equipped with a practical and solid shelf for tools. The maximum pressure force at a pressure of 6 atm is 735 kg, and at a pressure of 8 atm - 980 kg. The clamps have a quick-release grip, allowing you to move from a large to a small clamp without losing time.

- ▶ **Working pressure** - Atm: Min 6 - Max 10
- ▶ **Overall dimensions** - 140 x 65 x 40 cm.
- ▶ **Weight** - 72 kg.
- ▶ **Pressure force** - max kg. 735 (6 Atm)/kg. 980 (8 Atm.)



|              |          |                 |
|--------------|----------|-----------------|
| 007935060310 | included | Supporting vice |
|--------------|----------|-----------------|

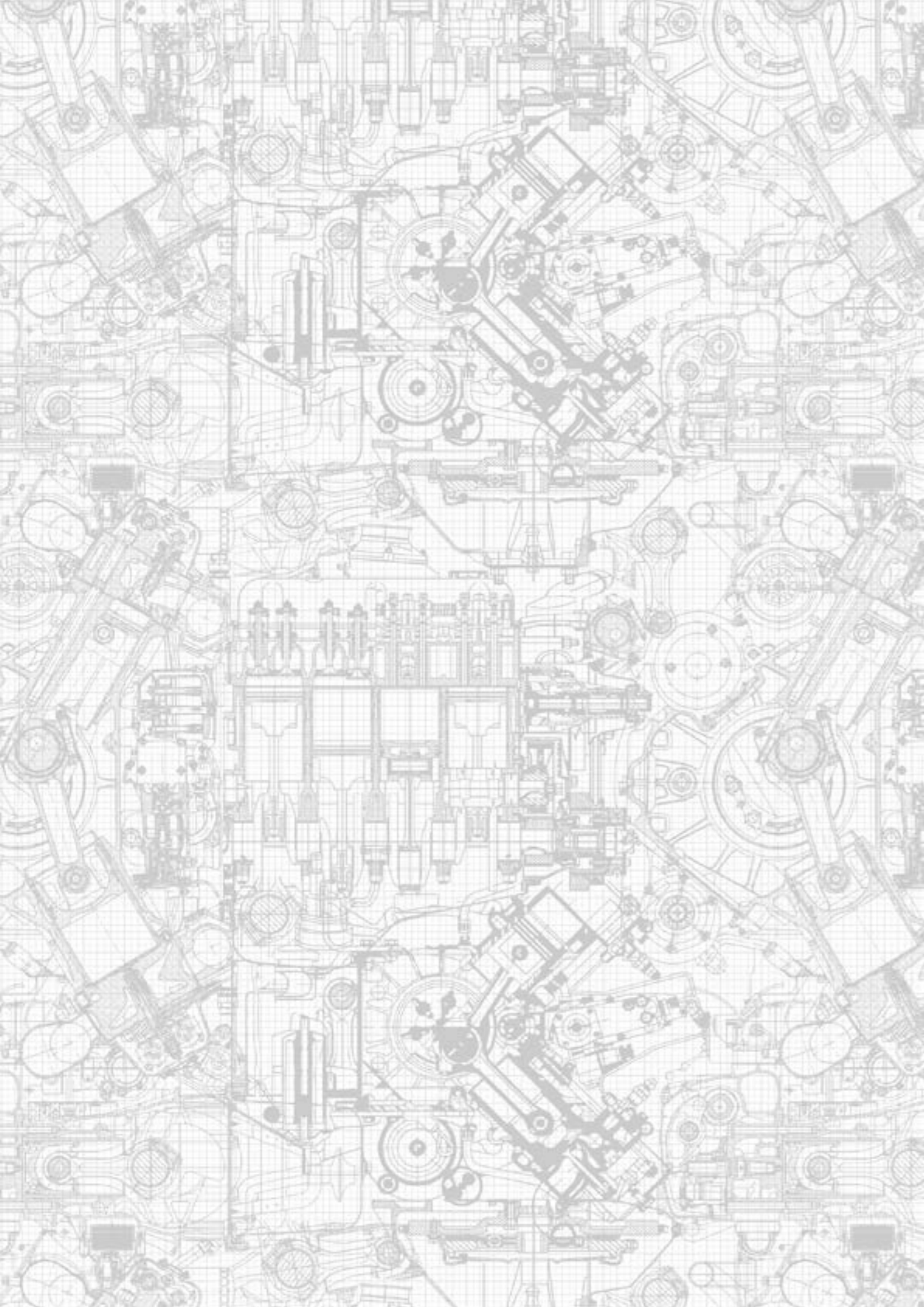

## TOOLS, WORKSHOP CHEMISTRY



**MM-OD1 Oil extraction decanter  
70L with quantity measurement**

- 007935016710
- Vacuum (MPa) 0-0.1
  - Inlet air pressure: 8-10 bar
  - Tank capacity: 70 l
  - Set of probes for sucking oil through the dipstick hole with different diameters
  - Suction capacity: 1.5 - 2 l/min
  - Tank discharge pressure: 1-2 bar
  - Oil temperature range: 40-80°C
  - Oil bowl capacity: 15 l
  - Device dimensions: 490x415x880 mm
  - Bowl dimensions: 420x200x100 mm
  - Weight: 25 kg
  - Plastic probe with a diameter of 6x700 mm
  - Plastic probe with a diameter of 8x700 mm
  - Plastic probe with a diameter of 7x1000 mm
  - Plastic probe with a diameter of 5x700 mm
  - Copper probe with a diameter of 6x700 mm
  - Copper probe with a diameter of 5x700 mm



**MM-OD03  
Oil extractor 70L**

- 007935016700
- Vacuum (MPa) 0-0.1
  - Inlet air pressure: 8-10 bar
  - Tank capacity: 70 L
  - Suction capacity: 1.5 - 2 L/min
  - Tank discharge pressure: 1-2 bar
  - Oil temperature range: 40-80°C
  - Dimensions: 500x420x890 mm
  - Weight: 18 kg
  - Plastic probe with a diameter of 6x700 mm
  - Plastic probe with a diameter of 8x700 mm
  - Plastic probe with a diameter of 7x1000 mm
  - Plastic probe with a diameter of 5x700 mm
  - Copper probe with a diameter of 6x700 mm
  - Copper probe with a diameter of 5x700 mm



**MM OD-05  
Oil decanter**

- 007935017095
- Tank capacity: 70 L
  - Tank discharge pressure: 1-2 bar
  - Bowl capacity: 15 L
  - Device dimensions: 500x420x890
  - Dimensions: 420x200x100 mm
  - Air inlet fitting: 1/4"
  - Weight: 25 kg



**MM-OD-07 Pneumatic  
lubricator with tank**

- 007935017130
- Inlet air pressure: 6-8 bar
  - Output pressure: 300-400 bar
  - Grease discharge rate: 400 - 600 g/min
  - Hose diameter: 1/4" x 4 m
  - Tank capacity: 13 kg
  - Pump output: 50:1
  - Dimensions: 370x350x850 mm
  - Weight: 12 kg



**MM-OD2 Oil extraction decanter  
80L with quantity measurement  
and control tank**

- 007935016720
- Tank capacity: 70 L
  - Control tank capacity: 10 L
  - Bowl capacity: 20 l
  - Set of probes for sucking oil through the dipstick hole with different diameters
  - Inlet air pressure: 6-8 bar
  - Vacuum: (MPa) 0-0.1
  - Tank discharge pressure: 0.7 - 1 bar
  - Oil temperature range: 40-80°C
  - Device dimensions: 500x420x890
  - Control tank dimensions: 270x270x470
  - Bowl dimensions: 420x200x100 mm
  - Weight: 29 kg
  - Plastic probe with a diameter of 6x700 mm
  - Plastic probe with a diameter of 8x700 mm
  - Plastic probe with a diameter of 7x1000 mm
  - Plastic probe with a diameter of 5x700 mm
  - Copper probe with a diameter of 6x700 mm
  - Copper probe with a diameter of 5x700 mm



**MM OD-04  
Oil decanter 70 L**

- 007935017090
- Tank capacity: 70 L
  - Inlet air pressure: 8-10 bar
  - Tank discharge pressure: 1-2 bar
  - Bowl capacity: 15 L
  - Device dimensions: 500x420x890
  - Bowl dimensions: 420x200x100 mm
  - Weight: 24 kg



**MM-OD-06  
Manual lubricator  
130-140**

- 007935017125
- Hose cross-section: 1/4"
  - Hose length: 4 m
  - Tank capacity 13 kg
  - Manual pump
  - Dimensions: 370x350x780 mm
  - Weight: 8 kg



**BF-12 brake fluid  
replacement device**

- 007935016730
- The units consist of a stainless steel reservoir, inside of which a rubber diaphragm is placed to assist in pumping brake fluid into the vehicle. Once the internal tank is filled and the maximum operating pressure is reached, the unit operates independently. It only takes one operator to top up the brake fluid. The kit includes service adapters, bushings and two 1L reservoirs.
- Working pressure: 0.7-3 bar  
Dimensions - 25 x 25 x 7.5  
- tank with a capacity of 6 litres  
Compression - 5 metres (compressed air)  
Pressure at the safety valve  
- 3 bar



**Oil and fluid distribution  
equipment**

- 007935013775
- Powered by an air compressor
- safe, environmentally friendly and non-sparking - the unit is used for filling lubricating and gear oil.



**Oil filling gun with  
electronic measurement**

- 007935017825
- Memory
  - Pre-selection
  - Manual valve
  - Flow rate: 1 to 30 L/min
  - Accuracy: ± 0.2%
  - Maximum working pressure: 70 bar
  - Minimum working pressure: 3 bar
  - Inner diameter: Ø 10



**Digital Meter Control  
Valve with electronic  
flowmeter and  
pre selection**

- 007935017085
- Electronic measurement
  - Memory
  - Pre-selection
  - Automatic valve
  - Flow rate: 1 to 30 L/min
  - Accuracy: ± 0.2%
  - Maximum working pressure: 70 bar
  - Minimum working pressure: 3 bar
  - Inner diameter: Ø 10



**Oil filling gun with electronic  
measurement**

- 007935017815
- Electronic measurement
  - Manual valve
  - Rigid probe
  - Flow rate: 1 to 25 L/min
  - Accuracy: ± 0.2%
  - Maximum working pressure: 70 bar
  - Minimum working pressure: 3 bar
  - Inner diameter: Ø 10



**Mobile oil  
distribution kit**

- 007935016760
- Pump output: 50:1
  - Intake pipe: 940 mm
  - Distribution gun with digital flow meter
  - Hose: 1/2" x 4 m
  - Kit for drums: 180-200 kg



**Oil filling gun**

- 007935016830
- Without electronic measurement
  - Automatic valve
  - Flow rate: 1 to 25 L/min
  - Accuracy: ± 0.2%
  - Maximum working pressure: 70 bar
  - Minimum working pressure: 3 bar
  - Inner diameter: Ø 10



**Oil filling gun**

- 007935016820
- Without electronic measurement
  - Manual valve
  - Flow rate: 1 to 25 L/min
  - Accuracy: ± 0.2%
  - Maximum working pressure: 70 bar
  - Minimum working pressure: 3 bar
  - Inner diameter: Ø 10



**Oil filling gun**

- 007935017080
- Electronic measurement
  - Memory
  - Automatic valve
  - Flow rate: 1 to 25 L/min
  - Accuracy: ± 0.2%
  - Maximum working pressure: 70 bar
  - Minimum working pressure: 3 bar
  - Inner diameter: Ø 10



**Used oil sump HC-48L**  
007935013765  
For combustion vehicles



**Channel tray for used oil HC-48LT**  
007935013770  
For combustion vehicles



**Oil drip tray - plastic**  
007935011040  
- Dimensions: 1320x670x420 mm  
- Capacity: 2x 220 L  
- Load capacity 1000 kg  
- Weight: 21 kg



**5:1 oil pump, 270mm**  
007935017100

- Feed: compressed air
- Pump output: 5:1
- Inlet air pressure: 3-8 bar
- Discharge volume with 4 m hose: 14 - 17 L/min
- Suction pipe: 270 mm
- Connection: 1/2"
- Weight: 5 kg



**Oil pump 5:1, 740 mm**  
007935017105  
- Feed: compressed air  
- Pump output: 5:1  
- Inlet air pressure: 3-8 bar  
- Discharge volume with 4 m hose: 14 - 17 L/min  
- Suction pipe: 740 mm  
- Connection: 1/2"  
- Weight: 7 kg



**5:1 oil pump, 940mm**  
007935017110  
- Feed: compressed air  
- Pump output: 5:1  
- Inlet air pressure: 3-8 bar  
- Discharge volume with 4 m hose: 14 - 17 L/min  
- Suction pipe: 940 mm  
- Connection: 1/2"  
- Weight: 12 kg



**Retractable cable on a reel**  
007935016800  
- Purpose: compressed air  
- Maximum pressure: 20 bar  
- Cross-section: 3/8"  
- Hose length: 15 m  
**Retractable cable on a reel**  
007935016810  
- urpose: oil  
- Maximum pressure: 138 bar  
- Cross-section: 1/2"  
- Hose length: 9 m



**Hand Oil Pump**  
007935016780  
- Pump output: 16 L/min  
- Telescopic suction pipe up to 1200 mm  
- Suitable for 60/200/220 litre drums



**Oil kit for 60L drums**  
007935017845  
- Intake pipe: 740 mm  
- Maximum pressure 40 bar  
- Max flow rate 14 L/min  
- Suction pipe diameter 30 mm  
- Distribution gun with digital timer  
- Hose: 1/2" x 4 m  
- Kit for drums: 40-60 kg  
- Preselection of quantity // 0.1L min, 99.9L max.  
- Flow rate 1 to 30 L/min  
- Accuracy ± 0.2%  
- Maximum working pressure 70 bar  
- Minimum working pressure 3 bar  
- Rotary inlet 1/2" BSP/NPT  
- Meter body input/output 1/2" BSP/NPT  
- Inner diameter Ø 10  
- DC 6V power supply  
- Outlet tube type: rigid tube  
- Automatic Discharge



**Swivel Bracket for The Wall**  
007935016790



**Mobile lubrication kit**  
007935017135  
- Drum 180-200 kg  
- Pump 50:1  
- Lance length 940 mm  
- Gun with Z-adapter  
- Hose 2 m



**Hose for oil pumps 4m**  
007935017155  
4 m



**Mobile oil distribution kit for 180-200 litre drums**  
007935016770  
- Pump output: 5:1  
- Filling gun with electronic measurement  
- Hose 4 m  
- Reel for 15 m of hose



**Drum/Barell trolley 20-60kg**  
007935017115  
- For a 20-60 kg drum  
- Pump mounting bracket  
- Handle height adjustment



**Mobile lubrication kit**  
007935017140  
- Drum 20-60 kg  
- Pump 50:1  
- Lance length 480 mm  
- Gun with Z-adapter  
- Hose 2 m



**Drum/Barell trolley 180-200kg**  
007935017120  
- For a 180-200 kg drum



## Pneumatic impact wrenches Maretti Marelli

Powerful 1/2" impact wrenches with two-way hammer mechanism and pressure lubrication system. Wrenches are available in 680, 860 and 1360 Nm versions.

To ensure smooth rotation and maximum power, pneumatic motors are equipped with high quality bearings.

The left/right rotation switch also provides a speed control function.



### Pneumatic wrench aluminium 1/2" 810 Nm RAPTOR

007936331040

#### Technical data:

- Square drive head: 1/2"(13mm)
- Capacity Bolt size: 5/8"(16mm)
- Speed (no load): 8500 RPM ±10%
- Working torque: 450ft-lb (610N.m)
- SCFM Requirement: 5cfm(142 l/min)
- Working pressure: 90PSI (6.3Bar)
- Air hose required: 3/8"ID
- Air inlet: 1/4" ID (6.35mm)
- A weighted sound pressure level: 106,6 dB (A)
- Sound power level: 94,6 dB (A)
- Weight: 1.45kgs(3.19Lbs)



### Angle pneumatic wrench 1/2" „FROG 67.5 Nm

007936331070

#### Technical data:

- Square drive: 3/8" or 1/2"(10mm or 13mm)
- Free speed: 160 rpm
- Max torque: 50ft/lb (67,5N.m)
- Air inlet size: 1/4"
- Air hose: 3/8" ID
- Avg. air consumption: 114 l/min ili 77 l/min
- Operating pressure: 90psi (6.3bar)
- A weighted sound pressure level LPA = 3 dB
- Sound power level LWA: 100.6dB(A) Kwa=3 dB
- Vibration in the handle ah,d: 8.47m/s2 K=1.33 m/s2
- Weight: 1,1 kg



### Pneumatic wrench composite 1/2" Trex 2200 Nm

007936331020

#### Technical data:

- 1/2" Socket Shank
- Twin Hammer
- Hammer System
- Maximum torque (reverse) 2200 Nm
- Operating torque 250 to 2000 Nm
- Free speed 7000 rpm
- Working pressure 6.3 bar
- 1" anvil length
- Net weight 2.0 kg
- 1/4" air supply
- Average air consumption 340 l/min



### Set of pneumatic sockets for alloy rims size 21,19,17-3 pcs

007936331030



### Pneumatic wrench aluminium 1" MAMUT 3100 Nm

007936331060

#### Technical data:

- Square drive: 1"
- Capacity Bolt Size: 1-3/4"(45mm)
- Free speed: 3600rpm
- Max torque: 2200ft-lb(3100N.m)
- Avg.air consumption: 40cfm(1140 l/min)
- Operating pressure: 90psi(6.3bar)
- Air inlet size: 1/2"
- Air hose: 5/8" ID
- Weight: 35.9Lbs(16.3kgs)



Cordless impact wrenches are tools designed to loosen and tighten bolts and nuts that require high torque. Powerful 20V brushless motors and effective overload protection hidden in the batteries ensure safe operation. Marelli's professional cordless impact spanners can handle any seized bolts of car or agricultural machinery wheels, as well as other jobs that require a lot of force to loosen bolted connections. They will relieve the strain on your arms, speed up the work you do and are just as powerful as a traditional air impact spanner. The 1/2" spindle models are equipped with two 4 Ah lithium-ion batteries and the 3/4" spindle model is equipped with two 8 Ah batteries. All spanners come with a quick charger for the batteries. The convenient speed and direction switch is illuminated by an LED. The „STOP" function prevents damage to the threads by stopping the spanner when the bolt is loosened. LED backlighting makes it easier to work in more difficult lighting conditions. The batteries have a 12-month warranty and last for approximately 1,000 charge cycles.

### Cordless impact wrench E-Lion 1/2" 620 Nm

007936331550



- ▶ Reinforced shank: 1/2"
- ▶ Rated voltage (V): 20 V
- ▶ Battery capacity: 4 Ah
- ▶ Battery type: Li-Ion
- ▶ Rotation speed: 2700/2300 rpm
- ▶ Impact frequency: 3600/3100 bpm
- ▶ Nut breaking torque: 620 Nm
- ▶ Weight: 2.34 kg (including battery)

### Cordless impact wrench E-Lion 1/2" 1700 Nm

007936331570



- ▶ Reinforced shank: 1/2"
- ▶ Rated voltage (V): 20 V
- ▶ Battery capacity: 4 Ah
- ▶ Battery type: Li-Ion
- ▶ Rotation speed: 1800/1200/900 rpm
- ▶ Impact frequency: 2200/2000/1800 bpm
- ▶ Nut breaking torque: 1700 Nm
- ▶ Weight: 3,45 kg (including battery)

### Cordless impact wrench E-Lion 3/4" 2400 Nm

007936331580



- ▶ Reinforced shank: 3/4"
- ▶ Rated voltage: 20 V
- ▶ Battery capacity: 8 Ah
- ▶ Battery type: Li-Ion
- ▶ Impact frequency: 2500/1900/1100 bpm
- ▶ Rotation speed: 1900/1500/1200 rpm
- ▶ Operating torque: 1850/1250/950 Nm
- ▶ Nut breaking torque: 2400 Nm
- ▶ Weight: 4,1 kg (including battery)

## COMPARISON TABLE

|                     | 007936331550                | 007936331570                | 007936331580               |
|---------------------|-----------------------------|-----------------------------|----------------------------|
| Shank               | 1/2"                        | 1/2"                        | 3/4"                       |
| Rated voltage       | 20 V                        | 20 V                        | 20 V                       |
| Battery capacity    | 4 Ah                        | 4 Ah                        | 8 Ah                       |
| Battery type        | Li-Ion                      | Li-Ion                      | Li-Ion                     |
| Impact frequency    | 3600/3100 bpm/min           | 2200/2000/1800 bpm/min      | 2500/1900/1100 bpm/min     |
| Rotation speed      | 2700/2300 bpm/min           | 1800/1200/900 bpm/min       | 1900/1500/1200 bpm/min     |
| Operating torque    | 620 Nm                      | 2200/2000/1800 Nm           | 1850/1250/950 Nm           |
| Nut breaking torque | 620 Nm                      | 1700 Nm                     | 2400 Nm                    |
| Product weight      | 2,34 kg (including battery) | 3,45 kg (including battery) | 4,1 kg (including battery) |

# See everything in a new light Magneti Marelli workshop lamps

High-quality workshop lamps from Magneti Marelli. The handy size and compact shape of the lamps, along with the high-power LEDs, allow for good illumination of hard-to-reach areas, making car maintenance work easier. The lamps use the latest COB or SMD diode technology, which allows for a powerful light output. The robust design and seals allow it to meet the exacting standards of IP54.

## 3W+3W swivel light

007935030030

Features and specification:

- 3W front COBLED provide >240 lumen
- 3W top SMD LED provide >160 lumen
- 120-degree rotation
- Magnet in the bottom part of the grip
- 'Nest'-type hooks in top/bottom part of the grip
- Charging port with battery level indicator
- Operation time: 2-3 hours
- Charging time: 3-4 hours
- 5V 1A CE Adapter with mini-USB cable



## 3W+UV Swivel light

007935030020

Features and specification:

- 3W front COBLED provide >240 lumen
- Top LED with UV , 395-410um
- 120-degree rotation
- Magnet in the bottom part of the grip
- 'Nest'-type hooks in top/bottom part of the grip
- Charging port with battery level indicator
- 2-3 hours of operation
- 3-4 hours charging
- 5V 1A CE Adapter with mini-USB cable



## 2.5W Folding lamp

007935030040

Features and specification:

- 2.5W COB LED provides >70/230 lumen
- Folding grip with magnet, 360-degree rotation
- retractable rotating hook/clamp, 360-degree rotation
- 3-4h of cont. operation
- 2,5-3h charging
- 5V 1A CE Adapter with mini-USB



## 15W SMD wired under hood light

007935030070

Features and specification:

- 15W SMD LED provides spot light, 450-550lm at half of power, 900-1150lm at full power
- Brightness push-button allows choosing half or full power
- ABS injection moulded grip with shock-resistant protection; ergonomic design for easy use
- Aluminium alloy hook with PVC cover, soft hook covers prevent scratching the vehicle body
- 47" to 75" adjustable bar; easy mounting to most trucks and SUVs.
- Finger hooks (360°) for safe and firm mounting



## Workshop lamp 300 lumen

007935030150

Features and specification:

- 3W front COB LED provide 50 lumen
- W top SMD LED provide do 300 lumen
- Two-range lighting power option 150 or 300 lumen
- Water and dust resistant (IP54)
- Two rotary integrated hooks with magnets
- Detachable hooks
- Charging time : 3-4h
- Operation time:3-6h
- Charging port



## MINI Workshop lamp

007935030140

Features and specification:

- 0.9W front COBLED provide 90-110l lumen
- 0.9W top SMD LED zapewniają 50-60 lumen
- 120-degree rotation
- Magnet in the bottom part of the grip
- Nest - type hooks in top/bottom part of the grip
- Charging port with battery level indicator
- 2.5-3h operation time
- incl. mini-USB



## Rotating garage lamp 0.9W COB LED + front light 0.9W UV mini

007935030130

Features and specification:

- 0.9W front COBLED provide 90-110l lumen
- Top LED z UV, 395-410um
- 120-degree rotation
- Magnet in the bottom part of the grip
- 'Nest'-type hooks in top/bottom part of the grip
- Charging port with battery level indicator
- 2.5-3h operation time
- incl. mini-USB



## Workshop torch

007935030160

Features and specification:

- 3W high-power LED
- Durable metal case
- Dust and water resistant (IP54)
- Ability to select power luminous intensity: 140 or 250 lumens
- Possibility to change the focal length lights
- Mini USB charging socket
- Charging time: 3-4 hours
- Working time 2.5-5 hours



## Headlamp 300 lum BATTERY POWERED COB LED

007935030190

Features and specification:

- COB LED provides 250/80Lumens
- Pivoting light head
- Two clips to attach to hard hat
- Adjustable and removable head band
- 3.8V 1600 mAh li-poly battery
- IP54 dust and water resistance
- 2.5/6 hours of running time
- 3-4 hours of charging time
- 5V 1A CE Adaptor with mini-USB connecting line

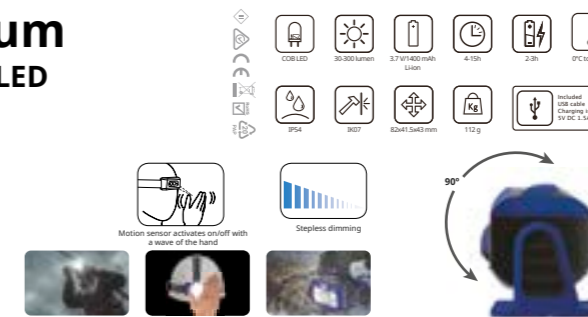

## Narrow head torch COB LED 500/250 lm

Top SMD LED 30lm 2600mAh Li-Ion

007935030230

Features and specification:

- COB LED provides 500/250 lm
- Top SMD LED provides 30 lm
- Ultra-thin wand-type LED lamp
- 360 degree rotation function
- Magnet at the bottom of the handle
- Integrated and retractable metal hook
- Brightness memory function
- Battery level and low battery information function
- Operating time 2/4 hrs.
- Charging time 3-4 hrs.
- With 5V 1A adapter



## Narrow head torch UV 395 COB LED 150/75

Top SMD LED 30lm UV LED provides 395nm 1200mAh

007935030240

Features and specification:

- COB LED provides 150/75 lm
- Top SMD LED provides 30 lm
- UV LED provides a wavelength of 395 nm
- Ultra-thin wand-type LED lamp
- 360 degree rotation function
- Magnet at the bottom of the handle
- Integrated and retractable metal hook
- Brightness memory function
- Low battery information function
- Operating time 3/6 hrs.
- Charging time 2-3 hrs.
- With 5V 1A adapter



## Working floodlight 3000 lm

COB LED 3000/2000/1000lm 6000mAh Li-Ion IP67 powerbank function

007935030260

Features and specification:

- COB LED provides 3000/2000/1000 lm
- Swivel bracket (360 degrees) can be attached to a stand
- Magnet at the bottom of the handle
- Heat transfer aluminium body
- Impact-resistant
- IP67
- Dimming function
- Power Bank function (output: 5 V 1 A)
- Operating time 2/3/6 hrs.
- Charging time 4-5 hrs.
- With 8.4 V 2.4 A charger and 5 metre cable



### Rechargeable & multifunctional area light series 1000lm

007935030310

Features and specification:

- High efficiency COB LED provides lights with up to 500/1000 lumens respectively
- Illuminance - much greater than traditional underhood lights
- Light angle - more focused than traditional floodlights, protecting user eyes
- Strong magnets for handsfree use
- Lamp can be 90° rotated for multi-angle illumination
- Glow-in-the-dark fluorescent reflector makes lamp easy to locate in the dark
- Flush mounted hook at back can be rotated for hanging
- IP54 dust and water resistant, drop impact resistant



OPTION - HOLDER FOR WORKING LAMPS  
500lm i 1000lm

007935030340



### Rechargeable & multifunctional area light series 500lm

007935030300

Features and specification:

- High efficiency COB LED provides lights with up to 500/1000 lumens respectively
- Illuminance - much greater than traditional underhood lights
- Light angle - more focused than traditional floodlights, protecting user eyes
- Strong magnets for handsfree use
- Lamp can be 90° rotated for multi-angle illumination
- Glow-in-the-dark fluorescent reflector makes lamp easy to locate in the dark
- Flush mounted hook at back can be rotated for hanging
- IP54 dust and water resistant, drop impact resistant



OPTION - HOLDER FOR WORKING LAMPS  
500lm i 1000lm

007935030340

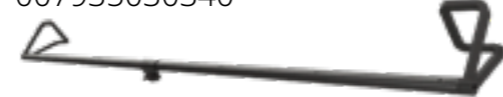

Hand Cleaning Paste 4 L  
099996001050



COLLECTIVE PACKAGING -  
4 PIECES.

Hand Cleaning Paste 4 litre  
099996001000



COLLECTIVE PACKAGING -  
12 PIECES.

#### Hand Cleaning Paste 4 L

Hand paste for professionals working in car repair shops and more. The paste's ingredients have been selected to ensure the best effectiveness when cleaning hard-to-remove dirt. The granules, which are part of the paste, allow for easy removal of dirt from oils, greases, also from places difficult to access. Glycerine, which is an ingredient of the paste, is a protection that helps keep the skin clean and at the same time prevents the skin from drying out. This helps to protect the skin from roughness and cracking.

Usage:

The paste is applied after drying the skin on the hands by rubbing and moistening with water. Continue until the dirt is removed. Then rinse the paste with water and pat the skin dry. It contains glycerine that is gentle on the skin. It cleans, leaving a delicate and pleasant fragrance - for special applications.

#### Liquid Hand Cleaning Paste with Pump 4.5 L

099996001040

A fully functional paste designed for professionals who want to keep themselves and their working environment clean, especially for those working in car repair shops. However, it can also be used in other working environments - by printers, carpenters and all those who are exposed at work to contamination of the body and working environment. The consistency of the paste is similar to that of hand cream for rough skin. The ingredients contained in the paste are perfectly proportioned to effectively clean soiled surfaces including the skin. Our product is composed of granules that easily and effectively remove all types of contaminants such as oil, grease and other soiling agents, even from places difficult to access. This type of paste contains glycerine which is gentle on the skin and prevents the effects of skin dryness by providing a protective layer for body parts coming into contact with soiled workshop elements.

This superbly effective product ensures perfect skin cleansing and is additionally equipped with a simple and convenient dispenser which ensures the appropriate dosage of the substance to clean e.g. hands.



COLLECTIVE PACKAGING -  
4 PIECES.

#### Professional Hand Cleaning Liquid Soap 1 L

099996001000

A fully functional liquid soap designed for professionals who want to keep themselves and their working environment clean, especially for those working in car repair shops. However, it can also be used in other working environments - by printers, carpenters and all those who are exposed at work to contamination of the body and working environment. The substance is in the form of a liquid applied to the skin to cleanse it. The ingredients contained in the liquid soap are perfectly proportioned to effectively clean soiled surfaces including the skin. Our product is composed of granules that easily and effectively remove all types of contaminants such as oil, grease and other soiling agents, even from places difficult to access. This type of product contains glycerine which is gentle on the skin and prevents the effects of skin dryness by providing a protective layer for body parts coming into contact with soiled workshop elements.

In addition to its benefits for excellent skin cleansing, this superbly effective product is equipped with a dispenser for easy and convenient use in work, ensuring the appropriate dosage of the cleaning substance to clean e.g. hands.



COLLECTIVE PACKAGING -  
12 PIECES.

|                       | Reflector working 3000lm   | Workshop lamp 300 lumen  | Narrow head torch   | Torch with narrow UV head | 250 Lumen Rechargeable Sensor Headlamp | 3W+3W swivel light       | 3W+UV Swivel light      | 15W SMD wired under hood light  | 2.5W Folding lamp   | Workshop torch 250 lumens | MINI Workshop lamp       | MINI Workshop lamp with UV | Workshop lamp 1000lm          | Workshop lamp 500lm     |
|-----------------------|----------------------------|--------------------------|---------------------|---------------------------|--|--------------------------|-------------------------|---------------------------------|---------------------|---------------------------|--------------------------|----------------------------|-------------------------------|-------------------------|
| MAIN LAMP (IN LUMEN)  | main source 3000/2000/1000 | main source 150-300      | main source 500/250 | main source 150/75        | main source 80-250                     | main source >240         | main source >240        | main source 900-1150            | main source 700-230 | main source 80-250        | main source 90-110       | main source 90-110         | main source 1000-500-100      | main source 500-250-100 |
| LIGHT REINFORCEMENT   | yes                        | yes                      | yes                 | yes                       | yes                                    | no                       | no                      | yes                             | yes                 | yes                       | no                       | no                         | yes                           | yes                     |
| HEAD LAMP (IN LUMEN)  | -                          | LED 50                   | 30                  | LED UV 395 nm             | 80-250                                 | upper >240               | LED UV 295-410 nm       | -                               | -                   | -                         | smd led 50-60            | LED UV 395-410 nm          | -                             | -                       |
| LED SOURCE            | 1x COB led                 | 1x COB LED<br>1x SMD LED | COB LED<br>SMD LED  | 1x COB LED<br>1x LED UV   | 1x COB led                             | 1x COB LED<br>1x smd LED | 1x COB LED<br>1x LED UV | 1x COB LED                      | 1x COB LED          | 1x LED                    | 1x COB LED<br>1x smd LED | 1x COB LED<br>1x LED UV    | 1x COB LED                    | 1x COB LED              |
| UV LIGHT              | no                         | no                       | no                  | yes                       | no                                     | no                       | yes                     | no                              | no                  | no                        | no                       | yes                        | no                            | no                      |
| INPUT USB             | yes                        | yes                      | yes                 | yes                       | yes                                    | yes                      | yes                     | no                              | yes                 | yes                       | yes                      | yes                        | yes                           | yes                     |
| CHARGING              | Battery                    | Battery                  | Battery             | Battery                   | Battery                                | Battery                  | Battery                 | 230V                            | Battery             | Battery                   | Battery                  | Battery                    | Battery                       | Battery                 |
| PROTECTION RATING     | IP67                       | IP54                     | -                   | -                         | IP54                                   | IP20                     | IP20                    | IP20                            | IP54                | IP54                      | IP20                     | IP20                       | IP54                          | IP54                    |
| CHARGING TIME         | 4-5h                       | 3-4h                     | 3-4h                | 2-3h                      | 3-4h                                   | 3-4h                     | 3-4h                    | -                               | 2,5-3h              | 3-4h                      | 3-4h                     | 3-4h                       | 3,5-4h                        | 2,5-3h                  |
| OPERATION TIME        | 2/3/6h                     | 3-6h                     | 2/4h                | 3/6h                      | 2,5-6h                                 | 2-3h                     | 2-3h                    | -                               | 3-4h                | 2,5h                      | 2-3h                     | 2-3h                       | 1,8-3,6-18h                   | 1,8-3,6-18h             |
| GRIP                  | Swivel bracket 360 degrees | Detachable rotary hook   | metal hook          | metal hook                | opaska na glowę                        | 2x 'nest' hooks          | 2x 'nest' hooks         | hook, 360-degree adjustable bar | hook, 360° rotation | -                         | hook, 360° rotation      | hook, 360° rotation        | 2 hooks rotatable 360 degrees | hook, 360° rotation     |
| MAGNET                | yes                        | Yes                      | yes                 | yes                       | no                                     | yes                      | yes                     | no                              | yes                 | yes                       | yes                      | yes                        | yes                           | yes                     |
| POWER CONSUMPTION (W) | 10W                        | 3W                       | 1,2W                | 1,2W                      | 3W                                     | 3W                       | 3W                      | 15W                             | 2,5W                | 3W                        | 0,9W                     | 0,9W                       | -                             | -                       |
| MM CODE               | 007935030260               | 007935030150             | 007935030230        | 007935030240              | 007935030190                           | 007935030030             | 007935030020            | 007935030070                    | 007935030040        | 007935030160              | 007935030140             | 007935030130               | 007935030310                  | 007935030300            |



**Marelli DEGREASER  
PRO 500 mL**  
99996001080

A powerful all-purpose degreaser, ideal for engine cleaning and suitable for any other similar purpose, easy to use. Designed to guarantee excellent dry cleaning performance, safe for any material and for any operator. This versatile agent can be used for degreasing and cleaning any part of the engine from any kind of dirt or stain. Super concentrated DEGREASER PRO, with the best Marelli technology applied to a modern detergent, is the most innovative of all multi-tasking technical degreasers. Powerful, fast and multifunctional, it offers unparalleled performance on any type of surface, with total safety thanks to its balanced pH. DEGREASER PRO is an easy and extremely effective solution to any grease removal or deep cleaning problem in 360°. This remarkable product, gladly used by top motorsport teams, is best at tackling stubborn dirt on cars, garages, boats, motor-bikes and even at home.

UFI code: WDG6-Q0XT-E00G-W6DE

Marelli DEGREASER PRO 500 mL Universal degreaser.

COLLECTIVE PACKAGING - 6 PIECES.

**Marelli Rapid Spray  
500 millilitres**  
99996001075

Thanks to its basic features, Rapid Spray is ideal for both large service centres and private users. Rapid Spray instantly dissolves rust to unlock coupled metal components such as joints, bolts and threads.

Thanks to its strong penetrating action, Rapid Spray allows the best rapid lubrication on any surface (such as padlocks or joints) without damaging the parts being worked on (even the most delicate parts, such as rubber or lacquer). Its universal dispensing valve allows it to operate at any angle and any position to the last drop.

UFI code: YQF6-P0EM-Y00H-MFQU Marelli Rapid Spray 500 mL.

Screw loosening agent, penetrating

COLLECTIVE PACKAGING - 24 PIECES.

**Freni Flush Brake  
Cleaner 500 mL**  
099996001035

For washing and cleaning the brake system and its components. Removes oil, grease, lubricants and all types of tarnish. Neutral for metal parts. Contains no lead, cadmium, acetone, FCKW, CKW corrosive or toxic substances. It evaporates quickly anywhere and anytime regardless of the nature of the work.

COLLECTIVE PACKAGING -  
24 PIECES.



**Marelli Multi Spray  
500 mL**  
99996001070

Perfectly lubricates any device. Unlocks, effectively working on jammed parts and frozen or blocked mechanisms. Protects, acting against oxidation and corrosion of all kinds.

The multi-tasking Multi Spray effectively performs seven basic functions: it lubricates any device perfectly, works quickly and ensures cleanliness, unblocks, effectively acting on jammed parts and frozen or blocked mechanisms, reactivates, quickly penetrating capillary into the pores of the metal, passing through corrosive layers, protects, acting against oxidation and all kinds of corrosion, also under the most critical conditions. It is water-resistant as it quickly permeates under moisture layer and covers any surface, thus preventing short circuits. Marelli Multi Spray is a cleaner easily removing grease, glue and tar stains from any non-porous surface; it is also a reconditioner, as it quickly restores the performance of any type of mechanism to its original level.

UFI code: QMF6-50R7-P001-Y44N

Marelli Multi Spray 500 mL.

Multi-purpose spray with a wide range of applications.

COLLECTIVE PACKAGING - 24 PIECES.



**Throttle Body Cleaner**  
- spray, 500 mL, 12 pieces  
007950027421

Cleaner and degreaser for mechanical parts of the car. A new, high-performance formula dedicated to the effective cleaning of throttle bodies and carburetors. Dissolves tarnish, carbon build-up, oils, dirt and sticky substances in seconds. The product promotes better functioning of moving parts and consequently reduces fuel consumption. Multifunctional mixture of aliphatic solvents, acetates, alcohols, without chlorinated solvents.

**ADVANTAGES:**

Quickly cleans throttle bodies, carburetors, starting devices, PCV valves for a professional result. Regular cleaning of the injection system and carburetor improves combustion and reduces harmful emissions in the exhaust gas.

**TECHNICAL FEATURES:**

Form - aerosol  
Colour - clear colourless  
Density - 0.80 kg/l (+/- 0.04) at 20°C (liquid phase)  
Propane/butane propellant  
Flammability - extremely flammable  
Store in a cool (10 - 30°C) and ventilated room, avoid the build-up of static electricity.  
Throttle Body Cleaner - spray,

500 mL - 12 pieces.

**Nitrile Gloves**

**M 100 pcs.** 099700120060  
**L 100 pcs.** 099700120070  
**XL 100 pcs.** 099700120080  
**XXL 100 pcs.** 099700120140



Protective gloves for demanding professionals who require hygienic and safe conditions in their workshops. This type of gloves is a must for every professional workshop. Our single-use gloves, made of a material called nitrile, are intended for specific working conditions in car repair shops. The gloves are manufactured from a safe, allergen-free material. They are extremely soft and resistant and can be worn on both sides. Their additional advantage is the lack of talcum powder which is unnecessary due to the materials used.

Our gloves are particularly resistant to substances such as:

- wide range of oils
- lubricants
- chemicals

The above qualities allow the gloves to be used for longer even in difficult conditions.

The product is characterized by a particular mechanical strength so it will not have to be replaced even in hard and demanding working conditions.

This is why our gloves are exceptionally strong.

We offer our gloves in three sizes: M, L, XL, XXL (black only).

The gloves are available in every size so it is worth taking the opportunity to choose the most suitable ones from our online catalogue.

Apart from their intended use in professional workshops, the gloves are also perfect for working at home and in the garden and not only there.

**EGR Valve Cleaning  
Fluid - spray 400 mL**  
- 12 pieces

007950027416

Cleaner and degreaser for mechanical car parts. The malfunctioning of the EGR system has a direct impact on emissions and can result in reduced engine performance. EGR Valve Cleaner has been specifically designed to clean and maintain EGR valves, allowing them to return to normal operation and performance.

**TECHNICAL FEATURES:**

Form - aerosol  
Colour - colourless liquid  
Density - 0.800 kg/l +/- 0.05 (liquid phase)  
Flammability - extremely flammable  
Fuel Gas - LPG (propane-butane)

NOTE: The preparation is intended for cleaning and degreasing DISMANTLED EGR valves. Use NEOPRENE gloves

EGR valve cleaning fluid - spray,  
400 mL - 12 pieces.

**Black nitrile gloves**

**M 100 pcs.** 099700141000  
**L 100 pcs.** 099700141020  
**XL 100 pcs.** 099700141040  
**XXL 100 pcs.** 099700141060



Diamond structure  
- anti-slip structure  
diamond-shaped allows  
for a firm grip and holding of tools.

## MAGNETI MARELLI CLOTHING COLLECTION

### Magneti Marelli T-shirt

|              |          |
|--------------|----------|
| 099990332323 | Size S   |
| 099990332324 | Size M   |
| 099990332325 | Size L   |
| 099990332326 | Size XL  |
| 099990332327 | Size XXL |



Comes with a practical fabric bag and an embroidered keychain.

### Magneti Marelli Polo Shirt

|              |          |
|--------------|----------|
| 099990332328 | Size S   |
| 099990332329 | Size M   |
| 099990332330 | Size L   |
| 099990332331 | Size XL  |
| 099990332332 | Size XXL |



Comes with a practical fabric bag and an embroidered keychain.

### Magneti Marelli Sweatshirt

|              |          |
|--------------|----------|
| 099990332333 | Size S   |
| 099990332334 | Size M   |
| 099990332335 | Size L   |
| 099990332336 | Size XL  |
| 099990332337 | Size XXL |



Comes with a practical fabric bag and an embroidered keychain.

### Magneti Marelli Jacket

|              |          |
|--------------|----------|
| 099990332338 | Size S   |
| 099990332339 | Size M   |
| 099990332340 | Size L   |
| 099990332341 | Size XL  |
| 099990332342 | Size XXL |



Comes with a practical fabric bag and an embroidered keychain.

### Magneti Marelli work pants

|              |           |
|--------------|-----------|
| 099720162425 | Size S    |
| 099720162426 | Size M    |
| 099720162427 | Size L    |
| 099720162428 | Size XL   |
| 099720162429 | Size XXL  |
| 099720162430 | Size XXXL |



### Magneti Marelli "dungarees" work pants

|              |           |
|--------------|-----------|
| 099720162413 | Size S    |
| 099720162414 | Size M    |
| 099720162415 | Size L    |
| 099720162416 | Size XL   |
| 099720162417 | Size XXL  |
| 099720162418 | Size XXXL |



### Magneti Marelli mechanic's coveralls

|              |           |
|--------------|-----------|
| 099720162401 | Size S    |
| 099720162402 | Size M    |
| 099720162403 | Size L    |
| 099720162404 | Size XL   |
| 099720162405 | Size XXL  |
| 099720162406 | Size XXXL |



### Magneti Marelli Sleeveless Jacket

|              |           |
|--------------|-----------|
| 099720162437 | Size S    |
| 099720162438 | Size M    |
| 099720162439 | Size L    |
| 099720162440 | Size XL   |
| 099720162441 | Size XXL  |
| 099720162442 | Size XXXL |



## MAGNETI MARELLI TRAINING

Magneti Marelli has a long-standing tradition of providing technical and marketing training. The company is constantly developing new training modules covering entire vehicles (MONOGRAPHY) or specific systems fitted to vehicles. To meet our customers' expectations, our training team comprises trainers with many years of professional experience and expertise in delivering technical training, supplemented by external trainers. Depending on our clients' needs and the complexity of the issue, we organise training courses lasting one or several days at various levels of difficulty. Our fully equipped Training Centre in Sosnowiec enables us to deliver courses covering both theoretical and practical aspects. Together with our business partners, we also organise training courses throughout Poland.

### Hybrid technology in Toyota vehicles



### ZF 8HP - construction, diagnostics, and maintenance



### Air conditioning systems in hybrid and electric vehicles



You can find our full range of training courses, along with the course outlines and schedule, on our website:

[www.magnetimarelli-parts-and-services.pl](http://www.magnetimarelli-parts-and-services.pl)  
(Products / Training tab).

If you have any questions, please contact:

**Michał Kosiński - +48 538 156 656**

**Rafał Wróbel - +48 602 430 632**





**Marelli Aftermarket Poland Sp. z o.o.**  
Plac pod Lipami 5, 40-476 Katowice, Poland  
Tel. +48 32 60 36 142  
Fax. +48 32 60 36 108  
e-mail: [wyposazenie@marelli.com](mailto:wyposazenie@marelli.com)  
[www.magnetimarelli-parts-and-services.pl](http://www.magnetimarelli-parts-and-services.pl)